

Northern
Harbors
& Small
Ports
Operation and
Maintenance

Alan Sorum

Published by
Alaska Sea Grant College Program
University of Alaska Fairbanks

MAB-56
\$20.00

Elmer E. Rasmuson Library Cataloging in Publication Data:

Sorum, Alan.

Northern harbors and small ports : operation and maintenance / Alan Sorum. –
Fairbanks, Alaska : Alaska Sea Grant College Program, University of Alaska
Fairbanks, 2006.

162 p. : ill. ; 22 cm. – (MAB ; 56) Includes bibliographical references and index.

1. Harbors—Cold weather conditions. 2. Harbors—Maintenance and repair—Cold
weather conditions. 3. Harbor masters—Cold weather conditions. 4. Marinas—Cold
weather conditions. I. Title. II. Sorum, Alan. III. Series: Marine advisory bulletin ; 56.

TC209.S67 2006

ISBN 1-56612-102-7

Credits

This book is published by the Alaska Sea Grant College Program, supported by the U.S. Department of Commerce, NOAA National Sea Grant Office, grant NA16RG2321, projects A/161-01 and A/152-20; and by the University of Alaska Fairbanks with state funds. The University of Alaska is an affirmative action/equal opportunity employer and educational institution. Funds for publishing were provided by the Alaska Department of Transportation and Public Safety, ADN no. 2553411.

Sea Grant is a unique partnership with public and private sectors combining research, education, and technology transfer for public service. This national network of universities meets changing environmental and economic needs of people in our coastal, ocean, and Great Lakes regions.

Book design is by Jen Gunderson, cover design is by Dave Partee, and editing is by Sue Keller. Front cover photo of Valdez, Alaska, and back cover photo of Sitka, Alaska, are by Kurt Byers.

Alaska Sea Grant College Program
University of Alaska Fairbanks
P.O. Box 755040
Fairbanks, Alaska 99775-5040
Toll free (888) 789-0090
(907) 474-6707 • Fax (907) 474-6285
www.alaskaseagrants.org



Contents

About the author	viii
Acknowledgments	ix
Chapter 1: Introduction	1
Chapter 2: Operations and maintenance planning	3
Marina operations manual	3
Facility policies and procedures	4
Customer documents	4
Valdez Moorage Agreement	6
Resource library	5
As-built drawings	5
O&M manuals	8
Inspections of the harbor facility	8
Determine frequency	8
Facility inspection forms	9
OSHA monthly checklists	9
Valdez Small Boat Harbor Monthly Facility Inspection Checklist	10
Harbor economics	11
Maintenance costs	11
Moorage rates	12
Economic impact of the harbor	12
Chapter 3: Fire safety	14
Fire safety training	15
Fire safety plan	16
Fire Safety Plan for Valdez Small Boat Harbor	18
Fire fighting equipment	23
Chapter 4: Facility safety	25
Power system	25
Valdez Boatyard Policies	26
Floating dock freeboard	28

Water rescue equipment	29
Personal protective equipment	30
Kids Don't Float Program	31
Housekeeping	32
Pedestrian falls	32
Lighting	33
Marine mammals in the harbor	33
Earthquake and tsunami dangers	35
Chapter 5: Hazardous and other materials: best management practices	38
Best Management Practices/Environmental Concerns	40
Used oil collection	41
Solid and liquid waste materials	43
Fishing line, fishing nets, and plastics	44
Plastic wastes best management practices	45
Hull scrapings and sanding products	45
Hull scrapings and sanding products best management practices	46
Scrap material generated by vessel repairs	46
Scrap material best management practices	47
Contaminated fuel or water	47
Liquid and aerosol paints	48
Liquid and aerosol paint best management practices	49
Lead-acid batteries	49
Lead-acid battery best management practices	50
Fish waste	50
Fish waste best management practices	51
Trash and garbage	52
Trash and garbage best management practices	52
Hazardous materials training	52
Chapter 6: Marine structures	54
Mooring docks	54
Wood floating docks	54
Concrete floating docks	56
Fixed docks	58

Anchor pilings	60
Tidal grids	62
Launch ramps	64
Valdez Harbor Launch Ramp Guidelines	65
Breakwaters	67
Rubble-mound breakwaters	67
Permeable wave barriers	68
Flexibility in design	68
Resistance to seismic damage	70
Environmental impacts	71
Floating breakwaters	72
Fish cleaning stations	72
Upland fish cleaning stations	72
Floating fish cleaning stations	72
Gangways	75
Chapter 7: Marine construction materials	77
Wood	77
Wood damage by organisms	78
Bacteria	78
Fungi	78
Insects	79
Beetles	79
Termites	80
Carpenter ants	81
Carpenter bees	82
Marine borers	83
Wood damage by nonliving agents	88
Wood-metal corrosion	88
Salt degradation	88
Chafing of timbers	89
Decay prevention	89
Keep moisture out	89
Wood preservatives	91
Creosote	92

Chromated copper arsenate	92
Ammoniacal copper zinc arsenate	92
Pentachlorophenol	92
Safety	92
Inspection for decay	93
Decay detection tools	95
Maintenance and repair of wood structures	97
Bullrails	97
Decking planks	97
Stringers	98
Cleats	98
Chocks	98
Steel	98
Dennis Nottingham's Method of Inspection for Open Cell Steel Bulkheads	99
Galvanic Series Chart	101
Concrete	103
Maintenance and repair of concrete surfaces	105
Foam flotation	106
Seven day Hunt absorption test for foam materials used as dock flotation	107
Chapter 8: Dockside cranes and straddle hoists	109
Dockside cranes	109
Crane inspections	110
Crane access control	110
Crane operator training	110
Marine straddle hoists	112
Chapter 9: Potable water systems	115
Chapter 10: Harbor electrical systems	118
Harbor electrolysis/corrosion	119
Galvanic corrosion	120
Electrolysis	120
Lighting systems	122
High-mast lights	122
Float-mounted lights	123

Piling-mounted lights	124
Chapter 11: Future developments in harbor operations . . .	125
Harbor maintenance management software	125
Harbor employee training	126
Port and facility security	126
References	128
Appendix A. Americans with Disabilities	
Act compliance	130
Appendix B. Harbor-related legislation, regulations,	
and programs	136
Appendix C. Trade and professional resources	144
Acronym glossary	147
Index	149

About the author



Alan Sorum, author and port director, Valdez, Alaska

Alan Sorum is port director for the City of Valdez, Alaska. The Port of Valdez operates a container facility, public dock, and small boat harbor. The Port of Valdez is host to large ship activity, with cruise liners, oil tankers, and ferries, as well as charter operations, naturalist cruises, commercial fishing, and recreational boaters. Valdez offers the primary access point to Prince William Sound for Interior Alaska. Alan has been with the City of Valdez for six years and has also worked for the ports of Wrangell and Whittier, Alaska.

Alan has been extensively involved with port and harbor planning efforts. The most recent projects are development of a marine center concept for the City of Valdez and a port operations plan for the Native Village of Eyak. Publications include an *Evaluation of Alaska's Commercial Fishing Vessel Safety Program* presented at IFISH II, National Institute for Occupational Safety and Health, Sitka, Alaska, 2003; and *Community Discovery in Chukotka* presented at the 55th Arctic Science Conference, American Association for the Advancement of Science, Anchorage, Alaska, 2004.

Alan is immediate past president of the Alaska Association of Harbormasters and Port Administrators, member of the Board of Directors for the National Harbormasters Association and Pacific Northwest Waterways Association, division captain for the Alaska Coast Guard Auxiliary, and vice-chairman of the Prince William Sound Area Maritime Security Committee.

Alan holds a bachelor of aeronautical science degree from Embry-Riddle Aeronautical University, a master of public administration from the University of Alaska Southeast, and a master of arts in rural development from the University of Alaska Fairbanks; and was recently designated a certified marina manager by the International Marina Institute.

Acknowledgments

A special thanks to the following professionals for their support and interest in making this project a success. Their insight and commentary factored greatly in making this handbook readable and relevant. There is a wealth of information available to harbor operators, and the following people truly have proven this point with their generous contribution of time and effort to this handbook.

Ruth A. Carter, P.E., Coastal Engineer for the Alaska Department of Transportation and Public Facilities

John Dailey, P.E., Consulting Engineer for Tryck, Nyman, Hayes, Inc.

James Fawcett, Seaport Specialist, University of Southern California Sea Grant

Terry Johnson, Alaska Sea Grant Marine Advisory agent, Homer, Alaska

Doug Kenley, P.E., Consulting Engineer for Peratrovich, Nottingham & Drage, Inc.

Jim Kruse, National Sea Grant Ports and Harbors Specialist, Texas Sea Grant

Eric Olsson, Marine Oil Spill Prevention Specialist, Washington Sea Grant

Nancy Peterson, Assistant City Manager for Valdez, Alaska

Adrian H. Rowland, P.E., Regional Engineer for Pacific Small Craft Harbours of Fisheries and Oceans Canada

Thanks to the following for graciously contributing mechanical and technical drawings for this handbook: Oregon Sea Grant, Peratrovich, Nottingham & Drage, Inc., Trick Nyman & Hayes, Inc., and Transpac Marinas. (Acknowledgment of private companies in this book does not necessarily indicate endorsement by the publisher.)

Thank you Ruth Knight.

1

Introduction

Small craft harbors and marinas in Alaska are typically designed to moor vessels that are less than 100 feet in length. Harbors represent a major investment in infrastructure that has been provided in large part by the State of Alaska, with local communities providing management and operational support of the facilities. Harbors range from having very limited dock space to more than a thousand mooring slips. Harbor staffing levels are generally representative of the facility size, and normally include employees that are responsible for business management, maintenance, and operation of the harbor.

Maintenance and operation of northern harbor facilities require the use of unique and challenging solutions by harbor employees, especially in our climate of chronic deferred maintenance and limited budgets. This book is meant to assist people already on the docks performing the tasks, and is not an exhaustive resource on harbor maintenance and operations. The engineering firm of Peratrovich, Nottingham & Drage, Inc. (PND) working with the State of Alaska developed the prototype of this maintenance book in 1988, and it still offers many ideas for use today. I especially like the cover photo of Valdez Harbor's tour dock float. PND has helped review the technical merits of this book and has offered me much operational support over the years.

I encourage harbor and port managers to share their knowledge and skills, which ultimately benefit the greater community. Ports, harbors, consulting engineers, equipment suppliers, and marine manufacturers should consider joining a regional professional organization like the Alaska Association of Harbormasters and Port Administrators (AAHPA) or Pacific Coast Congress of Harbormasters and Port Managers (PCC). Cooperation has repeatedly improved the shared knowledge base among our facilities in Alaska and the Pacific Northwest. Continuing education is very important for those involved in marina operation and maintenance to stay abreast of the

changing technology. There is great value in not having to reinvent the wheel. The AAHPA maintains an online library of documents available for other member facilities to utilize (see Appendix C).

This book includes several examples of programs already in place here in Valdez, Alaska. Structures in Alaska are little different from those in place in the Pacific Northwest. The chief difference in Alaska construction standards is the need for more robust structures built to withstand our severe climate. As a friend of mine once said, "If it will work here, it will work anywhere."

Topics in this book include developing a maintenance plan, conducting inspections, building a resource library, description of common construction materials, environmental impacts on building materials, descriptions of typical harbor and port structures, repair and maintenance techniques, and safety concerns.

2

Operations and maintenance planning

Proper operation of a harbor requires good planning. Several important documents should be developed for your facility to insure its safe and efficient operation. It is essential to complete self-assessment, resource inventory, and planning before you can schedule maintenance and provide adequate response to customer needs. Utilize examples of work done in other facilities and tailor them to best fit your needs. Many harbors maintain a running logbook of weather, events, customer complaints, incidents, and maintenance problems. Society has grown litigious over the years and a written record of your harbor activities could come in handy when a claim is made a year after an incident occurred.

Marina operations manual

One of the most important things a harbor manager can do is compile a customized, written operations manual. A written reference is essential in many ways. Staff and management need access to clear instructions for business procedures, emergency procedures, and personnel rules. Documentation is key in the defense of lawsuits. A good operations manual provides continuity and helps staff to bridge knowledge gaps caused by absences of key personnel, or the infrequent occurrence of emergency events.

The International Marina Institute (IMI) offers a marina operations manual package that gives you a very complete framework, which is then modified to match local conditions. (The package is available through the Association of Marina Industries, AMI.) It is a very effective approach to tackling a project of this scale and helps point out areas where your facility might consider improvements or new procedures. IMI makes a convincing argument that the better prepared

a harbor is in standardizing its management practices, the better the facility will be able to tackle new problems when they occur.

Facility policies and procedures

Facility policies and procedures (P&P) are important to the safe and efficient operation of a harbor. These documents outline customer rules and responsibilities in an understandable way. Topics of interest include general facility use, tenant responsibilities, wait list rules, vessel operations, waste disposal, electrical service, and boatyard policies. Policies and procedures documents are an important way to define environmental concerns and educate harbor users through best management practices. Ideally all documents related to operation of your facility are coordinated and designed to work together.

Don Jackson of the University of Florida Sea Grant program has developed a great resource for facility policies and procedures, called the "Panic Preventer File." The file provides staff with a ready guide outlining actions that should be followed in harbor related emergencies. The file is divided into color-coded tabs that relate to the severity of the problem. Life threatening incidents like medical emergencies or fires are in a red section. Boat accidents or overdue boaters are in a yellow section. The panic file also provides ready documentation of incidents by providing a form to fill out while also prompting staff that required actions to be taken.

The panic preventer file uses a four-step process to help your harbor deal with emergencies. Areas covered include basic facility information, contacts with local emergency responders, organizing or developing department policies and procedures, training staff in actions to be taken during an emergency, and annual review of the file to keep it current. Development of the file is a great safety training and familiarization tool for your staff. Employees are better able to handle stressful events, and customer service really shines when actions quickly meet public expectations during an incident. (You can buy the panic preventer file package [SGEB-45] from Florida Sea Grant, 1-800-226-1764, www.ifasbooks.ufl.edu.)

Customer documents

Customer documents should be tied to the overarching harbor policies and procedures. A section of your harbor's operations manual should contain each required form and a reference on its use. An example would be the coordination of a customer agreement for providing a boat lift. This form gives you a chance to inform the

customer of your environmental and safety requirements, gather payment and accounting information, and insure that legal language on “hold harmless” and indemnification is approved. An effective lift agreement requires coordination with safety standards, your legal and insurance representatives, and your finance department or accountant.

Slip contracts or moorage agreements are also an important area of concern to harbors. These user agreements are your chance to define payment terms, and address liability concerns, requirements for insurance, terms of compliance with local or regional regulations, allowable maintenance activities, and prohibited practices. The first contact your staff has with a new customer is the most important one. This is often your only chance to communicate harbor policies and procedures, and provide the customer with an understanding of what you expect. Consider developing a user’s handbook that contains useful information for a potential customer and determine what must be covered when a new vessel is registered in your harbor. See “Valdez Moorage Agreement” for an example of language that could be used as a basis for an agreement.

Resource library

A harbor manager should compile a collection of plans and “as-built” drawings for all the harbor facilities, and develop a library of documents describing facility resources.

As-built drawings

Construction projects are rarely completed as planned; contractors are required to submit as-built drawings to owners that detail the actual condition of the project, as it really exists upon completion. Based on this information, a facility site plan should be drawn to identify key features. This is particularly important regarding installation of underground utilities, and future attempts to locate them. New construction also must include good as-built information to coordinate integration with existing construction. Another area of concern for as-built drawings is proper identification of utility shutoff locations. Knowledge of shutoffs for services like gas, water, and power will be invaluable to future emergency responders.

Harbor managers need to develop a system that identifies the locations of various points in the facility. Most facilities already use numbers or letters to identify floats and mooring slips. Once you gather as-built drawings for your facility and draw a site plan, label

Valdez Moorage Agreement

This is a rental agreement between the City of Valdez, P.O. Box 275, Valdez, Alaska 99686, hereinafter called the "City" and the undersigned vessel owner, agent or operator, hereinafter called "Renter."

In consideration of the mutual terms and conditions set forth herein, City and Renter agree as follows:

1. Moorage Space. City rents to Renter moorage space as identified herein.
2. Rent. For such moorage space and other services received, Renter agrees to pay when due the fees and charges as established by the Valdez City Council; rates are subject to change.
3. Compliance with Laws and Regulations. Renter understands that the City has issued and may continue to issue such rules and regulations for the harbor and harbor area as the City in its judgment deems reasonable and necessary; and Renter agrees to comply with all rules, regulations, procedures and special instructions issued by the City and the harbormaster or his agents, including, but not limited to, the acts prohibited in VMC 11.04.160.

Renter hereby grants the City free access at all times to the vessel for purposes of inspection for compliance with this agreement, movement of the vessel, fighting of fire or other casualty or, at the discretion of the City, preventing any casualty or potential hazard. However, as provided in Paragraph 4, the City does not assume any responsibility for damage done to or by the vessel, its gear, equipment or contents by asserting the foregoing rights.

4. Waiver of Responsibility. It is mutually agreed that the City by entering into this agreement does not accept the vessel for storage, that the City is not a bailee or warehouseman of the vessel, and that the City shall not be liable or responsible in any manner for the safe keeping and condition of the vessel, its tackle, apparel, fixtures, equipment, gear, or furnishings. It is further agreed that the City will not be liable or responsible for any personal injuries or other damage suffered by Renter or his employees, agents, or invitees arising from any cause whatsoever upon the vessel, harbor facilities, or premises adjacent thereto, except if said injuries or damage are proven to have been proximately caused by the negligence of the City. Renter agrees to defend, indemnify, and hold the City and its agents and employees harmless from any loss, damage, or injury resulting from the acts or omission of Renter, his employees, agents, or invitees.
5. Assignment.
 - (a) Renter shall not assign, sublet, or otherwise transfer any interest in this agreement or the moorage space at the boat harbor.
 - (b) Renter agrees to notify the City within ten (10) days of the sale or transfer of any ownership interest in Renter's boat including the name and address of the purchaser or transferee, or the change of the vessel's operator, including the name and address of the new operator.
6. Termination by City. The City reserves the right to terminate this agreement and rights of Renter or Renter's assignees, sub-lessees, or transferees upon learning of any violation of this agreement including, but not limited to: Renter's violation of applicable Federal, State or Local laws, statutes, ordinances, rules, procedures or regulations, Renter's sale or transfer of his vessel without notifying the City, or Renter's charging any other person any money or other consideration for the use of the subject moorage space without prior written authorization from the City.

7. Condition of Moorage Space. Renter has inspected moorage space and the premises adjacent thereto and accepts them in their present condition. Renter agrees to keep them neat, clean, orderly, and free from all inflammable substances, and will at all times preserve the space in as good condition and repair the same as now or may thereafter be put to use, reasonable use and wear excepted. Renter shall dispose of sanitary waste, litter, trash, garbage, throwaway, or any disposable articles of any kind in proper receptacles. Renter shall not dispose of any items, including sanitary waste or petroleum products, overside.
8. Waiver. The failure of the City to insist upon strict performance of any term, condition, or covenant of this agreement, to exercise any right or remedy available on a breach thereof, or the acceptance of full or partial payments during the continuance of any breach shall not constitute a waiver of any applicable term, condition, or covenant of this agreement. Waiver of performance of any term, condition or covenant, or any breach thereof, shall be only by written instrument executed by the City. A waiver of any default shall not affect or alter any term, conditions, or covenant of this agreement, and those terms, conditions, or covenants shall continue in full force and effect with respect to any other subsequent default.
9. Non-waiver. Nothing contained in this agreement shall be construed as a waiver by the City of its right to arrest any vessel or boat to enforce a maritime lien under federal law or a waiver of other right or remedy under the laws of the State of Alaska.
10. Term. This agreement shall become effective on the date stated herein and shall remain in force until terminated by the City for default pursuant to paragraph 6 above, or by the Renter after thirty (30) days written notice has been delivered to the City.
11. Paragraph Headings. The captions and paragraph headings in this agreement are for the convenience of the parties only and do not limit, restrict, or otherwise amend the text language of any paragraph.
12. Notice to Renter. Billings and notices to Renter will be mailed to Renter at Renter's address as set forth herein. If Renter moves or desires to have billings or notices sent to another address, Renter shall notify the City in writing of the new mailing address. All billings and notices shall be deemed delivered upon first class mailing to Renter by the City.
13. Conflict of Laws.
 - (a) In the event any terms of this agreement conflict with any applicable Federal, State, or Local law, statute, ordinance, rule or regulation, the applicable law, statute, ordinance, rule, or regulation shall supercede said term and shall govern the relationship of the parties.
 - (b) The terms of this agreement shall be governed and interpreted by the laws of the State of Alaska.
14. Entire Agreement-Amendments. This writing constitutes the entire agreement between parties. No modification or amendment of this agreement shall be valid unless evidenced in writing signed by both parties.

Severability. If any clause or provision of this agreement is determined by a court of competent jurisdiction to be invalid, it shall not affect the validity of any other clause or provision of this agreement.

the plan using the location system you choose. Any inspection checklist developed for your facility should be keyed to the as-built drawings using this location system. Harbor signage should also reflect the system you develop. Providing good directions within your facility makes for good customer service and is a key requirement for prompt action by emergency providers.

O&M manuals

One of the key items delivered by a contractor to the facility owner upon completion of a project is an operation and maintenance or O&M manual for the structures and installations. Too often these manuals are archived or stored out of reach and out of mind. It is important to get a copy of all O&M manuals that are applicable to your facility, and keep them accessible. A typical O&M manual will include maintenance procedures required for installed equipment, copies of manufacturers' product cut sheets, and safety precautions to be taken by the owner in using the new facility.

O&M manuals often are a great source of information to be used in developing harbor facility maintenance checklists. The manuals will have catalog listings for components and a schematic drawing of the facility, and describe maintenance tasks like the tightening of floating dock through-bolts and required task intervals. It is also useful for collecting soil test data, construction notes, and photographs that will supplement your resource library.

Inspections of the harbor facility

Determine frequency

Inspections need to be tailored to the overall goals of the facility. Semi-annual inspections can focus on the state of the entire property and identify problems that may be important to correct prior-to-winter closure or preparing for the new season. A similar major inspection might be made after a major storm or natural disaster. Monthly inspections are more detailed and can focus on regulatory requirements. Daily inspections are important to identify safety concerns and to verify the welfare of moored vessels. Every inspection form used should have space available to note obvious hazards, damage, and worn or other noteworthy items. Operational planning must also include a mechanism for prompt correction of the problems uncovered during a routine inspection. Facilities

managers should consider a detailed engineering inspection every two years and an underwater inspection every five years for installed infrastructure.

Facility inspection forms

Development of your site plan and as-built library will provide direction on which parts of your facility should be inspected and how often. Checklists need to be developed to reflect this requirement and be based on this frequency of inspection. A daily inspection of a mooring basin will not entail the effort put into a preseason facility inspection. Every inspection form needs an area that can be used to document items in need of repair. This section is necessary to prompt the initiation of repair tasks. Repairs need to be documented at a number of points. These include the assignment of the initial task, completion of the task, and a cost accounting of the repair. Accurate budgeting of maintenance costs depends on a complete record of initial construction costs and periodic maintenance. This information is especially useful to support adequate moorage and user fees.

OSHA monthly checklists

This handbook is not meant to be a substitute for a consultation with your state occupational safety office. Most states offer excellent consultation and inspection services for harbors that are not centered on regulatory enforcement. Typically these visits require a commitment from the operator to correct problems identified in the inspection. Alaska's inspection program even offers a year's amnesty from the enforcement side of the agency if the harbor volunteers for a visit.

Occupational Safety and Health Administration (OSHA) requirements are based on identifying hazardous conditions present in a work environment. Identifying hazardous conditions will also identify many maintenance problems. A loose plank on a floating dock can be found during a regular inspection; its repair helps extend the life of the facility and reduces the potential for personal injuries. Good maintenance practices reduce risk of injury to the public and your employees, which impacts the bottom line. Facilities are required by OSHA to visually inspect fire extinguishers once a month. The Valdez Small Boat Harbor Monthly Facility Inspection Checklist can be used during each fire extinguisher inspection. Operations with dockside cranes also have inspection requirements that are detailed in the section on "Dockside cranes" in this book.

Valdez Small Boat Harbor Monthly Facility Inspection Checklist

Date:	Inspection Results			
Area	Sat	Unsat	N/A	Comments
Trip hazards				
Phone cords				
Steps				
Handrails				
Spills				
Holes				
Gangway surfaces				
Electrical hazards				
Overloaded circuits				
Exposed wiring				
Outlet covers				
Proper power cords				
Extension cords				
Illumination				
Adequate levels				
High mast bulbs				
Emergency Exits				
Fire extinguishers				
Cabinet cover in place				
General condition				
Gauge in green				
Hose in good condition				
Pin is installed				
Cabinet lock installed				
First aid kits				
Installed properly				
Required items present				

Valdez Small Boat Harbor Monthly Facility Inspection Checklist (continued)

Date:	Inspection Results			
Area	Sat	Unsat	N/A	Comments
Powered equipment				
Proper grounding				
Serviceable				
Proper location				
Secured				
PPE nearby				
Material storage				
Shelving/racks secure				
Loads are safe				
Materials compatible				
Hazard class apparent				
General housekeeping				
Clean, neat, and orderly				

Harbor economics

Maintenance costs

Communities encumber a huge amount of capital in their waterfront facilities. The question always arises as to how much should be spent on annual maintenance. The Alaska Department of Transportation and Public Facilities (DOT&PF) and the U.S. Army Corps of Engineers (ACOE) worked together on several studies to quantify the amount of money that should be allocated for harbor maintenance and replacement. A formula is summarized in the following paragraphs. Estimates are based on original costs for a facility discounting mobilization, demobilization, contingencies, design, and administrative costs.

During construction of a new harbor is an ideal time to consider maintenance and replacement costs based on current costs for construction. The maintenance and replacement plan would follow this timeline: during the first five years of the project, 2.5% of the value should be reserved for annual maintenance. Funds not spent for maintenance should be reserved for facility replacement. After the first five years, 5% should be set aside for maintenance and replace-

ment. Industry practice is to expect floats and other major structures to last at least 30 years. Life span will be extended with appropriate maintenance.

Using an example of a project being proposed in Valdez, for which total estimated construction costs are \$18,000,000, projected maintenance and replacement cost during the first five years would be \$450,000 per year, and after this period \$900,000 per year. These costs are probably on the high side. Once the actual cost of the new harbor is established and life cycles are established, a better cost estimate can be used in these calculations, but these figures provide a realistic starting point. This level of funding would cover routine maintenance and provides a fund for replacement of floats after thirty years of service.

Maintenance costs should also include the costs associated with boat lifts, pumps, dockside cranes, and other mechanical equipment needed to operate the facility.

Moorage rates

A moorage rate established to capture the cost of operations, maintenance, and replacement would be a total of these costs divided by total billable moorage in feet. A survey of your harbor's total available billable moorage needs to be developed. The total facility cost divided by the available billable moorage would yield a moorage rate per foot per year. This calculation will produce a moorage rate that may seem high for those of us boating in Alaska. It should be noted that federal, state, and local governments have heavily subsidized harbor construction in Alaska. This calculated rate would reflect an appropriate charge (without profit) that a private party would need to charge to protect their investment. An understanding of the actual cost of harbor operation, maintenance, and replacement is important in the discussion of overall moorage rates. Even if the moorage rate charged does not meet cost recovery requirements, a city government needs to weigh this information against the substantial economic benefit of harbor development to the community. This equates to an informed decision in the consideration of moorage rates.

Economic impact of the harbor

Harbors are important economic engines for their surrounding communities. A calculation of the economic impact generated by a boat harbor can be made using assumptions provided in research conducted by Northern Economics, Inc., and DOT&PF. The treat-

ment of this subject begins with a harbor fleet design, identification of the fleet mix, quantifying expenses generated by each user group, calculation of total economic impact, and a summary of its importance to the community. Patrick Burden, of Northern Economics, Inc., presented a set of guidelines for estimating the economic impact made in the community by the operation of ports and harbors at the Alaska Association of Harbormasters and Port Administrators 2002 annual meeting. Burden identified three different measures of value to the community—financial impact, fiscal impact, and economic impact. These values represent three different bottom lines that contribute to the local economy.

Financial impact is the total of harbor revenue, payroll, and local purchases. Fiscal impact is the total spending by nonlocal and local harbor users, as well as the taxes generated by harbor users and related businesses. Economic impact is the combination of total spending modified by a multiplier, new income and export-oriented commercial spending modified by the same multiplier, and additional employment caused by the harbor's presence in the community. It is an accepted economic principle that new and outside income brought into a community is spent a number of times. A larger community is better able to provide goods and services than a smaller one.

Knowledge of your facility's economic impact is of crucial importance in any discussion of maintenance and operational funding. Harbors hold substantial value to their host community and warrant proper support for care and maintenance.

Alaska DOT&PF sponsored a harbor economic modeling project with Northern Economics, Inc., that seeks to quantify the actual economic impact generated by Alaska harbors. Preliminary results for Valdez Harbor show a local benefit of \$24 million per year and harbor related employment of 269. This project is exciting from the standpoint of justifying the vital need for financial support of harbors by local and state government.

3

Fire safety

Mooring basins represent some of the highest property values found in any coastal community. Vessels over 50 feet in length are routinely valued at more than a million dollars and many 30-foot vessels are worth more than \$100,000. Harbors by their very nature concentrate vessels into close quarters with densities of up to 25 vessels per acre. One float system mooring large fishing and recreational vessels could easily have \$20,000,000 worth of boats tied to it.

Boats are often built of flammable materials or contain flammable substances like oil and fuel. The average width of a finger float is four feet, which means fire aboard one vessel is easily spread to adjacent vessels. Improperly designed covered moorage can also accelerate the spread of fire between boats. Rapid response by vessel



K. BYERS

A harbor like this one can have millions of dollars worth of boats. An effective fire safety plan is essential to prevent huge losses in damage.

operators and harbor employees is vital in preventing substantial damage caused by a fire in a marina.

Fire safety training

Marina Training.com is providing one new source of training available to harbors in staff fire training, at www.marinatraining.com. Current offerings are online courses in fire safety and marina fuel attendant. Once a student is registered with Marina Training.com, they receive a username and password to enter the online course. The student has 20 days to complete the course and the results of testing are forwarded via email. A certificate of completion is mailed upon successful progress in the course.

A harbor's community fire department is an excellent source of support and training in fire safety. Fire departments recognize the importance of building partnerships and have good institutional training programs in place. Training with your local fire department is an important component of a successful fire safety plan. Many training tasks are easy to complete and make great improvements in emergency response to fires and other problems. This training can



Vessel fire in Valdez Harbor, Alaska. Fire aboard a moored vessel can easily spread to adjacent vessels.

include contacting the fire department, evacuation procedures, and use of fire extinguishers.

A number of questions should be discussed with harbor staff and the fire department concerning responsibilities of both groups.

- How far should the harbor staff go in fighting a fire?
- Who is allowed to board a vessel in the harbor?
- Who will be pumping the vessel during fire suppression activities?
- When are initial responders relieved by the fire department?

Fire safety plan

Every harbor should have a written policy in place that defines the minimum acceptable standards to keep life and property safe from fire and electrical hazard in the facility. The National Fire Protection Association (NFPA) 303 standard for marinas and boatyards addresses what should be included in a viable fire safety plan. A copy of this standard can be purchased from NFPA at www.nfpa.org. Harbor managers are responsible for planning and implementing a program that adequately addresses fire safety, prevention, and protection.

Items that should be addressed in a fire safety plan include the followings topics.

- **Management.** Location of equipment, record-keeping standards, housekeeping, maintenance of equipment, training, liaison with the local fire department, and boat watch services.
- **Electrical Wiring and Equipment.** Compliance with the National Electric Code, adequate capacity standards for shore power cords, and approved lamps or heaters.
- **Fire Protection.** Portable fire extinguisher installations, planning for review of fixed fire systems as part of new construction, transmittal of emergency communications, and use of smoke detectors.
- **Berthing and Storage.** Wet storage and berthing arrangement, heater use in dry storage areas, storage practices for lead-acid batteries, and battery charger use.
- **Operational Hazards.** Welding equipment use, application for hot work permits, inspection of vessels prior to acceptance for storage, posting of safe operating procedures, designation of approved fueling areas, approval for fuel containers, and required safety equipment for customers who self-fuel their vessels.



K. EYERS

The fire safety plan should address compliance with the National Electric code, and adequate capacity standards for shore power cords.

The fire safety plan is not a large document and should be kept in a three-ring binder for ready reference. Using the binder provides a space to document facility/fire extinguisher inspections, notes concerning fire related incidents, and staff training in fire safety. See the Fire Safety Plan for Valdez Small Boat Harbor.

Fire Safety Plan for Valdez Small Boat Harbor

This fire safety plan has been prepared in the spirit of requirements established by the National Fire Protection Association (NFPA) Fire Protection Standard for Marinas and Boatyards, NFPA 303. The following plan applies to facilities operated by the Harbor Department of the City of Valdez, Alaska. These standards will define the minimum acceptable level of safety to life and property from fire and electrical hazards that occur within harbor facilities. Management of the Valdez Small Boat Harbor (VSBH) is responsible for planning and implementing a program that addresses fire safety, prevention, and protection. The Harbor Department's attitude toward fire safety is reflected in the actions of our staff and harbor users.

Management

Location: VSBH will place detailed map placards at the head of each ramp to assist emergency personnel responding to the harbor. The placards will detail slip identifications and locations of fire safety equipment.

Record Keeping: Written records will be kept by VSBH that describe identification, location, purchase date, and current inspection date of all fire safety equipment within our facilities.

Cleanliness: VSBH will maintain its facilities in a state of general order and cleanliness. No unconfined trash, wood waste, or other debris will be allowed. Facilities will be kept free of open containers containing flammable or combustible liquids. Spills of oil, paint, or fuel will be avoided. Covered containers will be provided throughout VSBH facilities for disposal of garbage and trash.

Shop: Shop floors will be cleaned daily. Covered metal containers will be provided for the storage of oily rags. Smoking will be prohibited and signs posted in any area used to store fuel or other flammable liquids.

Maintenance: All fire safety equipment will be inspected and maintained on a yearly basis or after use. This includes fire extinguishers, fire hose, nozzles, and pumps. Walkways, piers, access roads, dock, and floats will be kept clear of obstructions that would limit safe access by fire equipment.

Training: Selected VSBH personnel will train with the Valdez Fire Department (VFD) at least twice a year. Training will include basic fire fighting skills, pump use, and fire systems. Management will stress cooperation between the two departments. All VSBH employees will be trained in properly reporting a fire and the use of portable fire extinguishers.

Fire department liaison: The VFD will be encouraged to visit VSBH on a regular basis to become familiar with harbor facilities. VSBH will assist the Fire Department with any fire preplanning efforts

that apply to harbor facilities. VSBH will make information available to the Fire Department concerning extinguisher locations, standpipe systems, fire hydrant locations, safety equipment available, construction standards, and any other information necessary for effective preplanning. Harbor residents will be encouraged to contact the VFD through 911 in the event of a suspected fire or other emergency.

Watch service: VSBH will provide funding for a night watch, in cooperation with the Port of Valdez, during the harbor's peak user season.

Electrical wiring and equipment

- Electrical systems and equipment used within VSBH facilities will comply with NFPA 70, National Electrical Code and Chapter 3 of NFPA 303.
- Cords with current carrying capacity of less than fifteen (15) amps will not be used. Flexible cords will be used only in continuous lengths without splicing or taps.
- Cords, attachment plugs and connector bodies will not be smaller than required for the rated current of the attached cord or connected equipment.
- Infrared heating lamps may only be used with porcelain type sockets.
- Any heater capable of causing a fire if overturned must be equipped with a safety switch that will disconnect electric current to the heater if overturned.
- The following power cord types are approved for use: SO, ST, STO, POW, K, S.
- The following power cord types are not approved for use: SP3, SPT3, TP, TPT, TS, TST, AFC, AFPO, CFC, CFPO, CFPD, PO1, PO2, PO, SPT1, SPT2, SP1, C, PD, P1, P2, P, PW1, PW2, SV, SVT, SJ, SJO, SJT, SJTO.
- Any cord not listed must be inspected and approved by the harbormaster prior to its use.
- Maximum allowable current-carrying capacity of flexible cords is as follows:

AWG	14	12	10	8	6	4
AMPS	15	20	25	35	45	60

Fire protection

Portable fire extinguishers: A 10-pound ABC dry chemical portable fire extinguisher will be provided at the end of each float that extends more than 25 feet. Floats that exceed 75 feet in length

will have a 10-pound multi-purpose dry chemical portable fire extinguisher placed every 75 feet along the float. Vessel storage yard aisle-ways will have a 10-pound ABC dry chemical portable fire extinguisher placed every 100 feet so that an extinguisher is within 50 feet of any stored vessel.

Fixed fire extinguishment systems: New VSBH construction projects will include a plan review from the State Fire Marshall and will consider use of fixed fire extinguishment systems.

Transmittal of Fire Emergency: VSBH will provide a telephone to allow for notification of fire emergencies. This telephone will require no payment to contact 911. The local emergency number, 911, will be posted by the telephone.

Fire detectors: A smoke detector will be installed in the VSBH office and shop. Smoke detectors will be installed in other areas at the direction of the Fire Chief. Smoke detectors will be tested monthly and their batteries will be replaced yearly.

Berthing and storage

Wet storage and berthing: Each berth will be arranged to allow a vessel to be removed safely in the event of an emergency. Ready access to the vessel for fire equipment will be provided. Electrical lighting will be provided that assures adequate illumination of all exterior areas, piers and floats.

Outdoor dry storage: The use of portable heaters within the boat storage area is prohibited unless the heater is needed for the repair of the vessel and there is person attending the heater while it is being used. Ladders sufficiently tall to reach the deck of any stored vessel will be readily available. The use of blowtorches or flammable paint remover is prohibited.

Battery storage: Lead-acid type batteries should be removed for long-term storage and recharging. If it is impractical to remove the battery, the batteries may remain onboard provided:

- The battery compartment has adequate ventilation.
- A listed charger is in use.
- The power connection to the charger consists of a three-wire cord, with not less than #14AWG conductors, attached to a 120 volt single phase current system using a control switch and approved circuit protection.
- There is no connection on the load side of the charger from this circuit to any other device.
- The battery is properly connected to the charger and the grounding conductor effectively grounds the charger enclosure.
- Unattended battery chargers should be checked every two hours.

Operational hazards

Welding equipment, torches or open flames: No person will use welding equipment, a burning torch or any other open flame or conduct any hot work within VSBH without a hot work permit issued by the Valdez Fire Chief. VSBH and the VFD will be notified when the hot work is completed.

Conditions on individual boats: VSBH may have an inspection made of boats received for storage. This inspection will determine if there is the presence of any combustible vapors onboard, general cleanliness and condition of the vessel, fire safety equipment available onboard and appropriate power connections. Storage may be refused until the condition of the vessel is corrected.

Posting of safe operating procedures: VSBH will post a list of safe operating procedures for harbor users. The operating procedures will include information on fueling, use of charcoal cooking equipment, disposal of trash, nonsmoking areas, location of fire safety equipment and procedures for making a fire alarm. These procedures are at the end of this document.

Fueling areas: Commercial fueling operators will have an operations plan approved by the U.S. Coast Guard and abide by it. The City of Valdez will designate fueling areas.

Preferred Location: VSBH users will fuel their vessels at designated sites or outside of the mooring basin.

Fuel containers: Gasoline, heating oil and other flammable liquids carried to vessels within VSBH will be transported in approved containers especially designed for storage and carrying of these liquids. Glass jars, open pails or cans will not be used to carry flammable or combustible liquids within VSBH. Do not leave any fuel container on the floats or docks.

Safety equipment: VSBH users self-fueling their vessels will use approved containers and have a 10-pound ABC dry chemical portable fire extinguisher at hand. Self-fueling of vessels within the mooring basin is prohibited. The use of oil adsorbent socks and pads while fueling is required.

Valdez Small Boat Harbor safe operating procedures (to be posted)

Avoid using hibachis or charcoal grills on wooden floats or docks and/or near fueling areas.

- No smoking near designated fueling areas.
- Portable fire extinguishers are located along the mooring floats.
- In the event of a fire or other emergency, call 911 from the telephones located at the top of gangways or near the harbormaster's office.
- Please dispose of trash and garbage in the containers provided at the top of each gangway ramp.

Fueling procedures

Before fueling

- Stop all engines and auxiliaries.
- Shut off all electricity, open flames, and heat sources.
- Check bilges for fuel vapors.
- Extinguish all smoking materials.
- Close access fittings and openings that could allow fuel vapors to enter the boat's enclosed spaces.
- Remove all personnel from the boat except the person handling the fueling hose.

During fueling

- Maintain nozzle contact with fill pipe
- Fuel filling nozzle must be attended at all times.
- Wipe up spills immediately.
- Avoid overfilling.

After fueling and before starting engine

- Inspect bilges for leakage or fuel odors.
- Ventilate until odors are removed.



K. BYERS

Fuel docks in Valdez Harbor, Alaska. Before fueling, stop all vessel engines and shut off electricity and heat sources.

Fire fighting equipment

There are many tools available to harbors for extinguishing fires. The most obvious is strategic placement of dry chemical extinguishers along all floating docks and public spaces. Many floating docks have dry or wet fire standpipe systems available for ready use by the local fire department. A facility with standpipe systems in use can place fire hose racks at hard-to-reach locations. Many harbors utilize portable pumps and fire hoses to extinguish fires. The company Marina Fires.com, at www.marinafires.com, has several different cart-mounted fire extinguishing systems available for use in harbors.

Another way to improve customer service and fire safety is the addition of adequate informational signage. Valdez harbor installed informational signs at the head of each gangway leading into the harbor. These signs show a complete layout of harbor floats, locations of standpipes and fire extinguishers, slip numbers, and identification of other harbor features. These signs assist visitors in finding their way around the harbor, but more importantly they help first responders quickly locate a slip in an emergency.

Most harbors make an effort to provide fire extinguishers at fixed intervals along their floats and docks. The Federal Code of Regulations 29 CFR 1910.157(e)(2) requires that harbors develop an inspection and maintenance program for their portable fire extinguishers. Insuring annual inspections of fire extinguishers by a certified inspector and making monthly visual inspections of the fire extinguishers on your facility easily meet this requirement. Taking the time to check the fire extinguishers every month also presents a great opportunity for an even more thorough safety inspection of your facility. Consider adopting the use of a facilities inspection checklist, which can be tailored to the unique needs of your harbor.



K. BYERS

Informational signs at the head of each gangway, like the one on the far left, improve fire safety. The sign shows float layout and slip numbers, and locations of standpipes and extinguishers.



K. BYERS

A 10 pound ABC dry chemical portable fire extinguisher should be installed at the end of all floats that extend more than 25 feet.

4

Facility safety

The Valdez Small Boat Harbor Monthly Facility Inspection Checklist, on page 10, can be changed readily to suit your operations. Safety items are noted on the form, but another important function is to provide an opportunity to identify maintenance problems that need to be corrected. This action allows maintenance problems to be found early, and there is often a direct relationship between safety and maintenance concerns. Once the checklist is completed, it should be reviewed with staff and appropriate repairs should be scheduled. Place the completed checklist in your Fire Safety Plan binder to provide a record of compliance with OSHA and as a ready reference for required maintenance tasks.

Some items of interest in a facility safety inspection include the power system, floating dock freeboard and condition, availability of water rescue equipment, conditions that might cause slips or trips, inadequate lighting, hazardous materials use, and collection of used oil.

Power system

There are several safety issues related to the use of harbor electrical systems. Failure to follow industry standard can cause death, injury, fire, and damage to moored vessels. Harbor systems should be designed to comply with the National Fire Protection Association (NFPA) Code 303 for marinas and boatyards, and the National Electric Code NFPA 70. Both of these standards are part of the Uniform Building Code, which has been adopted by most communities in the United States.

Power system safety is dependent on the use of approved electrical systems by the harbor and use of proper shore power cords and correctly wired vessels by harbor customers. A good harbor policies and procedures document, and fire safety plan, will have recommendations on proper electrical plugs and cords for vessel

Valdez Boatyard Policies

1.1 Vessel maintenance pads

- A. Vessel owners shall schedule their use of the Vessel Maintenance Pads with the harbor office.
- B. Length of use may be limited if facility is reserved to capacity.
- C. Electrical power and water are available at the Maintenance Pads. Fees for use shall be established by Resolution of the Valdez City Council.
- D. Vessel owner is required to clean the work area after any maintenance work on a vessel is completed.
- E. Vessel owners shall contact the harbor office if there are any problems noted with the Vessel Maintenance Pads.
- F. Vessel owners shall ensure that the planned maintenance activity is an approved activity in the boatyard. Contact the harbor office with questions regarding approved activities.

1.2 Electrical power

- A. No power provided in the boatyard will be used without making prior arrangements with the harbor office.
- B. Electrical systems and equipment used within Valdez Small Boat Harbor facilities will comply with National Fire Protection Association (NFPA) 70, National Electrical Code and Chapter 3 of NFPA 303.
- C. Cords with current carrying capacity of less than fifteen (15) amps will not be used.

1.3 Storage

Valdez Small Boat Harbor staff may have an inspection made of boats received for storage. This inspection will determine if there are any combustible vapors onboard, general cleanliness and condition of the vessel, fire safety equipment available onboard, and appropriate power connections. Storage may be refused until the condition of the vessel is corrected.

- A. The time limit for storage in the boat yard will be nine (9) months. The harbor office maintains a list of alternate vessel storage facilities.

1.4 Blocking

- A. Blocks and jack stands must provide a minimum bearing area of 576 square inches (24 inches x 24 inches) or use a plywood pad provided by harbor staff.
- B. No steel drums shall be used as blocking.

1.5 Environmental concerns

- A. Vessels that will be hauled out for more than a month will have an approved oil absorbent pad placed beneath the keel.
- B. Appropriate material is available from harbor staff.
- C. Any maintenance work that involves an oil-based product (i.e., changing engine or outdrive oil) will be conducted within the boatyard. No maintenance work of any kind will be conducted at the launch ramp.
- D. Used oil shall be disposed of properly. Contact the harbor office for options.

- E. Drip pans shall be used when handling any type of liquid and separate drip pans shall be used for each fluid to avoid mixing types of fluid.
- F. All petroleum spills shall be captured with absorbent pads and materials. Notify the harbor office of any oil product spill.
- G. For winterizing, use propylene glycol antifreeze for all systems; it is less toxic than ethylene glycol. Use the minimum amount of antifreeze necessary for the job. Ethylene glycol should never be used in potable water systems; it is highly toxic and cannot be purged reliably.
- H. Do not fill fuel tanks more than 90% full.

1.6 Paint removal activities

Any maintenance involving blasting, chipping, sanding, or other abrasive removal of material or paint shall be done over canvas or plastic tarps. If water blasting is conducted, filter fabric may be used instead of canvas or plastic tarps to allow water to pass through.

These activities shall be done in an enclosed or sheltered structure or in a tarped enclosure to contain airborne debris and dust. Use of vacuum sanders and equipment is encouraged to collect and retain material. Vessel must be moved away from other vessels in laydown area.

Work areas shall be cleaned after each operation is completed or at least at the end of the day. Remove all trash, debris, paint chips, fiberglass, blast grit, residue, etc. All resulting material from paint removal will be collected and disposed of properly. This material shall not be disposed of in the trash, or construction materials dumpsters, unless tested and approved for such disposal by an environmental services company approved by the City. Sand and paint chips will be accepted at the City of Valdez Baler Facility only with a certification from a testing facility stating that the paint is not lead based. The baler facility charges a fee for this service.

If paint tests high lead base, the sand and paint chips must be sealed in barrels and shipped to a facility that will accept hazardous waste materials. Contact the City of Valdez Baler Facility (835-2356) for more information on facilities that will accept these materials.

The use of blowtorches or flammable paint remover is prohibited.

1.7 Fire safety

- A. Hot work will not be conducted in the boatyard without a permit issued by the Harbormaster or Fire Chief.
- B. Welding and cutting activities will only be conducted in an area assigned by the Harbormaster.
- C. Store opened containers of useable solvents and paints in covered, UL-listed, or Factory Mutual Approved containers.
- D. Fuel tanks shall be 85-90% full to prevent flammable fumes from accumulating and to minimize the possibility of condensation leading to corrosion.
- E. The use of portable heaters within the boat storage area is prohibited unless the heater is needed for the repair of the vessel and there is a person attending the heater while it is being used.

shore power. Allowing the use of common household extension cords or automotive battery chargers are common mistakes seen in harbors. Examples of these documents are the Valdez Boatyard Policies (page 26) and the Fire Safety Plan for Valdez Small Boat Harbor (page 18).

Floating dock freeboard

Floating dock freeboard is a measure of how far out of the water a dock extends. Harbor operators are concerned with inadequate flotation in floating docks. Decomposed foam flotation or heavy imposed loads like snow can cause freeboard to be lowered. The chief danger of low freeboard is the chance the dock will fail under additional load or upset with people walking across it.

Another consideration is having a floating dock with excess freeboard. Excess height can impact the ability of vessels to moor and make it very difficult for a person falling into the water to get out again.



Scott Brown, harbormaster for Dutch Harbor/Unalaska, shows a ring life buoy (RLB) at Valdez Harbor. RLBs should be installed every 75 feet on the floats. Brown uses the same life rings in his harbor.

Water rescue equipment

Harbors are increasingly providing more equipment on their docks to help rescue a person who has fallen in the water. A traditional tool is the ring life buoy (RLB) with an attached line. RLBs should be installed in highly visible cabinets spaced about 75 feet apart. Another useful tool is called a throw bag. Throw bags contain between 40 and 60 feet of high-strength line that can be thrown easily to a person in the water. Harbor staff members who are given a little practice can consistently hit a target 40 feet away twice within 20 seconds. This performance is much better than can be accomplished with a ring life buoy.

Provide time for harbor staff to train with ring life buoys and throw bags every six months. This training improves the chance of a successful water rescue, and looks good on your OSHA safety training log. It also insures that equipment is occasionally removed



Safety ladder, installed according to Transpac Marinas mechanical drawing, in Valdez Harbor, Alaska.

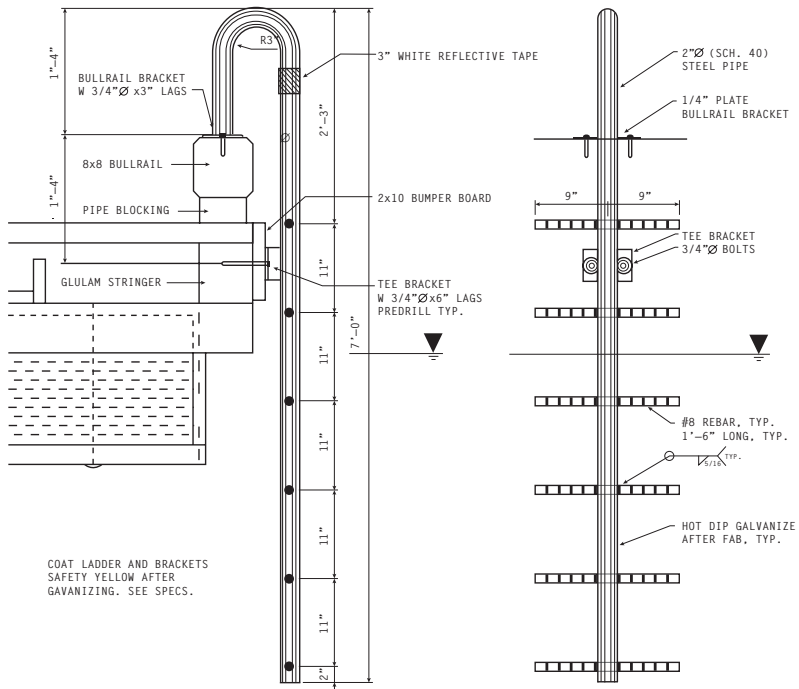

This safety ladder is very effective for self-rescue of people who fall in the water. Floating docks have a freeboard height of over 16 inches, and they make it difficult to climb out of the water. These ladders can cost around \$150 each, installed. Courtesy Transpac Marinas.

from its container, inspected, and used. Most coastal community fire departments have a dive or swift water rescue team that would likely enjoy training with the local harbor staff.

Safety ladders are becoming more popular in Alaska and along the Pacific Northwest coast. The design shown here, from Transpac Marinas, is very simple to build, easy to install, and works well.

Personal protective equipment

Harbor employees should always wear a personal flotation device (PFD) while on board skiffs or when conducting work that requires them to hang over a dock. Recent PFD designs are greatly improved, and many harbor employees routinely wear USCG approved float coats as a matter of course. Both the Stearns and

Mustang companies offer approved automatic inflation PFD suspenders that are very comfortable to wear. An added benefit of PFD use by employees is the excellent example it sets to encourage harbor users to wear PFDs.

Kids Don't Float Program

The Centers for Disease Control documented 135 drowning deaths of Alaska children under age 14, from 1981 to 2002. In 1995, the Kids Don't Float Program was developed by Homer Fire Department chief Bob Painter, through a state grant, to help reduce drowning of school-age children. Kids Don't Float was adopted in 1997 as a statewide program for Alaska, now serving over 61 communities.

The program has two components. (1) It provides personal flotation devices (PFDs) for children at harbor, dock, and launch ramp loaner stations. The PFDs are loaned on the "honor" system, and do not have to be checked out. Many harbors also provide adult-sized life jackets at their loaner stations. (2) It provides safe boating and PFD education in the public schools. One focus of this educational effort is the promotion of peer-to-peer education. The program educates high school students as trainers, who then return to their schools to promote the program to younger classmates.



The Kids Don't Float Program lends PFDs to school-age children in 61 Alaska coastal communities.

A number of agencies contribute PFDs and promotional information to the program. These include the Alaska Department of Health and Social Services, Southeast Alaska Regional Health Center, BoatUS Foundation, Alaska Office of Boating Safety, Alaska Safe Kids, and the 17th District of the United States Coast Guard and Coast Guard Auxiliary.

Housekeeping

Housekeeping is very important in the reduction of risks that could cause injuries or incidents. A key feature of any harbor inspection should be identification of anything that could cause a future problem if left unattended. This could be fish slime on a dock or oily rags left in the harbor shop. Poor housekeeping is a common, but easily prevented cause of many OSHA reportable accidents. Taking time to clean up facilities will reduce risk of injury and reduce insurance costs.

Pedestrian falls

Slips, trips, and falls represent the greatest open-ended liability faced by any facility that allows pedestrian access. Harbors present any number of different risks, ranging from steep gangways to narrow finger floats. The most important part of any daily facility

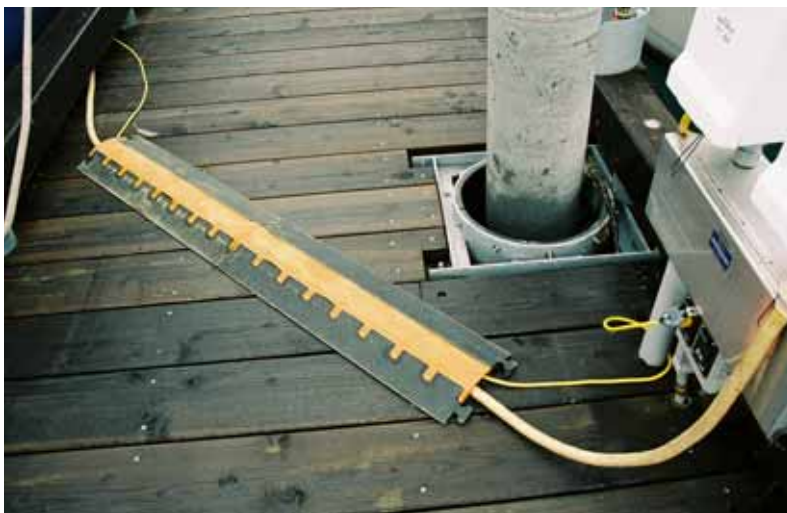

To prevent tripping hazards, cover cords that are lying on the dock.

inspection is identification and immediate repair of tripping hazards. Warning signs should be posted at problem sites if repairs cannot be made immediately.

There are many potential causes of slips, trips, and falls. Some things that can be looked for are shore power cords laid across docks, broken deck planks, loose carpeting, inadequate handholds, broken ladders, and loose equipment left on the docks.

Lighting

Effective lighting can dramatically improve safety in a harbor. Lighting can prevent inadvertent falls, discourage theft, and facilitate response to emergencies. Most lighting systems are adequate for illuminating docks; high mast lights will also illuminate the areas in fairways between boats. This is especially helpful if there is an effort being made to locate a person in the water.

Marine mammals in the harbor

Harbors are attractive to wildlife, as well as those who enjoy watching the wildlife. Protected marine mammals often choose an Alaska harbor as their home. The Marine Mammal Protection Act of 1972 (MMPA) prohibits harassment of marine mammals, and defines



K. BYERS

Marine mammal protection sign posted in Valdez, Alaska.

harassment as any action that causes disruption in the animal's normal behavior. Threatened and endangered species are afforded additional protection under the Endangered Species Act.

The National Marine Fisheries Service (NMFS) and the U.S. Fish and Wildlife Service (USFWS) are the two federal agencies that have jurisdiction for marine mammal management in Alaska under the MMPA. The USFWS manages polar bears, sea otters, and Pacific walrus in Alaska. NMFS is responsible for managing all marine mammals that are not dealt with by the USFWS, including whales, porpoises, seals, and sea lions.

It is important to educate harbor users of the dangers and problems associated with feeding sea lions. It is dangerous and illegal to touch or harass a sea lion. Feeding a sea lion could encourage it to take up permanent residence on the harbor docks. Boaters who feed sea lions could lose access to their boat slips when the sea lion decides to haul out on the boat dock, blocking their way and making it difficult to pass without getting uncomfortably close to the animal. Feeding can disrupt normal eating patterns and habituate animals to human contact. Habituated animals have a much greater chance of being struck by boats or becoming aggressive toward people on the docks, while anticipating the source of their next meal. In Western Alaska, a few years back, a man put some herring in his back pocket and was feeding and teasing a sea lion. The sea lion took a bite out



K. BYERS

In Kodiak Harbor Steller sea lions have access to a dock, placed exclusively for them in an out-of-the-way location.

of the seat of the guy's pants, landing him in the hospital! In fact, several people and dogs have been bitten by sea lions in Alaska harbors. In March 2004, a fisherman was even pulled off his boat and into the waters of King Cove by a sea lion.

NMFS has a "Don't feed the sea lions" program and will send signs to harbors that request them. NMFS will help harbors deal with disruptive sea lions, as well as disruptive boaters who are feeding them. Contact NMFS enforcement in Alaska at (800) 853-1964, (907) 586-7221, or (907) 271-5006 if you have sea lion problems, or other marine mammal problems.

Harbors have used "scarecrows" and wind streamers to discourage sea lions from hauling out on their docks. Kodiak Harbor went one step further and installed a set of old floating docks in a back corner of the harbor dedicated to exclusive use by sea lions. Now the sea lions have their own place in the harbor and summer tourists love to watch them from the shore or while boating.

If you see an injured or abandoned marine mammal, keep dogs and people from approaching or disturbing the animal. Contact local NMFS or other enforcement officers with information on the animal's location and condition. Be prepared to describe any injuries noted; take digital photos of the animal and its immediate surroundings if possible. Enforcement officers will instruct you on what to expect next and what actions to take. Local NMFS enforcement officers are aware of other groups in their towns who are authorized to respond to marine mammal strandings, and will tell you to contact them if appropriate.

Earthquake and tsunami dangers

Alaska coastal communities and their harbors have the same elements of earthquake risk experienced by inland communities. A more pressing concern for harbors is the chance of a tsunami event being generated by a severe earthquake.

There are two common mechanisms for the production of a tsunami wave. The first is the shifting of the seafloor during an earthquake, which can produce a wave that travels long distances. The arrival of the waves, almost imperceptible to a vessel in deep water, can often be predicted. The second is a severe local wave caused by the sloughing of soils in a submarine landslide during an earthquake. These locally generated waves can occur without warning. Much of the damage to "Old Town" Valdez in the 1964



COURTESY OF RUTH BRECHMAN

In 1964, a major earthquake sent multiple tsunamis through coastal towns in Alaska, killing more than 100 people. In Kodiak (above) the tsunamis sent boats careening through the inundated downtown area.

earthquake was caused by a wave generated by an underwater landslide. Tsunamis can also be generated by volcanic eruptions, meteor strikes, or nuclear explosions.

A boat harbor is likely one of the worst places you can be during a tsunami event. Tsunami waves generated in the open ocean are characterized by long periods between wave crests. The height of the wave in deep water may be only a few inches. Tsunamis are not a single wave, but rather a series or train of waves, reaching speeds of 500 miles per hour. As tsunami waves reach shallow waters, they slow down and gain height. The increased wave height, and effects of harbor structures on local currents, cause major safety problems for people and vessels in a mooring basin. Tsunamis can come in as fast-moving, monster-high waves. Vessels that are at sea should not return to port while a tsunami warning is in effect.

A tsunami generated in mid-ocean may be detected in time to issue a warning to potentially impacted communities. There may be an opportunity for vessel owners to take boats out into water that is at least 100 fathoms (600 feet) deep. Any decision to do this must be based on the vessel owner's personal evaluation of the risk,

and should not impact the safety of other harbor users or vessels. It is probably safer for owners of smaller vessels to just leave them moored and retreat to a safer location. This is especially true if there is severe weather during the tsunami event. Harbormasters and vessel owners need to maintain close contact, and coordinate their response, with the Coast Guard. Vessels that are out to sea during a tsunami should avoid returning soon after a wave strikes the harbor. Tsunamis are a series of waves and the first one ashore may not be the worst one. Damage caused by a tsunami can also make harbor facilities unsafe to use.

The response strategy to a locally generated tsunami wave, with little time to react, is limited to having people leave the harbor and other low-lying areas. Warning signs of local waves can include an extreme change in tide, a loud roaring noise, or strongly felt earthquake lasting more than 20 seconds.

Coastal communities in Alaska have been working to reduce the risk posed by tsunamis. Tsunami warnings are issued by the West Coast/Alaska Tsunami Warning Center in Palmer, Alaska, to emergency management agencies throughout the state and on the Web at wcatwc.arh.noaa.gov/message.shtml. There is also a community-based program called "TsunamiReady" which uses inundation maps generated at the University of Alaska Fairbanks to identify safe evacuation routes and safe areas. The Web address for this program is wcatwc.arh.noaa.gov/tsunamiready/tready.htm.

5

Hazardous and other materials: best management practices

Harbor operators have made great strides in cleaning up their facilities and raising the awareness of users concerning pollution. Unfortunately many harbor customers are unaware of their impact on the environment caused by improper disposal of chemicals or incorrect maintenance procedures. Routine activities like engine oil changes, hull cleaning, painting, and fueling can introduce harmful chemicals into the environment.

Across the United States, ports and harbors have begun to use what are called best management practices (BMP) to prevent or reduce the level of pollutants discharged into the soil, air, and water. These pollutants are referred to as “nonpoint source” when they are not found within a single discharge or waste stream, and “point source” when the origin is readily identifiable. Pollution in a harbor comes from many different products like diesel fuel, bottom paint, solvents, and ethylene glycol that find their way into our water.

BMPs are guidelines that must be adjusted to best fit the needs of each community. BMPs are broadly divided into those that prevent pollution and those that treat it. Prevention is the ideal method of handling a potential pollutant. Treatment is less effective since it is after the fact. The potential audience for BMP education is your harbor’s staff and customers.

Our regulatory environment today demands that harbors address the impacts their operations make on the environment. Any facility operator contemplating an expansion project will need to assure natural resource and regulatory agencies of their ability to limit potential pollution. Our state harbor association has begun work to develop a statewide clean marina program similar to many

other states to get ahead of this issue. This is an area of concern for harbors where it is much better to become proactive rather than wait for a regulatory hammer to fall.

Operational activities that can benefit from the use of BMPs include sewage collection, fueling of vessels, vessel maintenance including hull work and engine oil changes, ethylene glycol antifreeze disposal, fish cleaning and waste handling, oil spill prevention and response, and management of hazardous materials. This book covers some of the more important problem areas, and includes an example set of best management practices (Best Management Practices/ Environmental Concerns, page 40). The Alaska Coastal Management Program has a copy of Alaska Best Management Practices for Harbor, Marina and Boat Operations online at www.alaskacoast.state.ak.us/ACMPGrants/6217/docs/HarborBMPmanual.pdf.



Sewage pumpout station in an Alaska harbor. The Clean Water Act prohibits dumping raw sewage in U.S. waters.

Best Management Practices/ Environmental Concerns

- Work areas shall be cleaned after each operation is completed or at the end of the day. Remove all trash, debris, paint chips, fiberglass, blast grit, and residue, etc. All maintenance shall be conducted in designated areas.
- Any maintenance involving blasting, chipping, sanding, or other abrasive/abrasive removal of material or paint shall be done over canvas or plastic tarps. If water blasting is conducted, filter fabric may be used instead of canvas or plastic tarps to allow water to pass through. These activities shall be done in an enclosed or sheltered structure or in a tarped enclosure to contain airborne debris and dust.
- Collected paint chips, dust, sediment, blast grit, and similar debris shall be placed in containers approved for such material and disposed of according to federal, state, and local regulations. This material shall not be disposed of in the trash or construction materials dumpsters.
- Anti-fouling paints containing the minimum amount of toxin necessary for the expected conditions is strongly recommended. Avoid the use of soft abrasive paints and use water-based paints where possible
- Minimize the use of spray-painting equipment on vessels. Use brushes and rollers whenever possible. Spray painting is prohibited over water. Designate an area to mix paints, solvents, and reducers. Keep records of paint use, type, application, amount required, etc. All spray painting shall be conducted over land in a spray booth or under a tarp.
- Store opened containers of useable solvents and paints in covered, UL-listed, or Factory Mutual approved containers. Use only one cleaning solvent to simplify disposal and use only the minimal amount of solvent needed for a given job. Use soy-based solvents and other similar products with no or low volatility.
- Store engine parts and engines on impervious surfaces. Do not wash engine parts over bare ground or water. Adopt alternatives to solvent-based parts washers such as bioremediating systems that take advantage of microbes to digest petroleum. If using solvent to clean engine parts, do so in a container parts washer with a lid to prevent evaporation of volatile organic compounds. Use drip pans when handling any type of liquid and use separate drip pans for each fluid to avoid mixing. Use funnels to transfer fluids and drain all parts of fluid prior to disposal. Clean engine repair areas regularly using dry cleanup methods. Capture petroleum spills with absorbent pads and materials. Do not hose down the repair area with water.
- Winterizing: Use propylene glycol antifreeze for all systems; it is less toxic than ethylene glycol. Ethylene glycol should never be used in potable water systems; it is highly toxic and cannot be purged reliably. Add stabilizers to fuel to prevent degradation. Be sure fuel tanks are 85-90% full to prevent flammable fumes from accumulating and to minimize the possibility of condensation leading to corrosion. Do not fill the tank more than 90% full. Use the highest rated octane recommended by the engine manufacturer; premium fuels are more stable than others are. Be sure the gas cap seals tightly.
- There may be additional requirements mandated by Alaska Department of Environmental Conservation, various federal and state regulations, and/or other regulatory agencies. You are required to know and comply with these regulations as well.



K. BYERS

Used oil collection site, where harbor users leave covered containers of oil.

Used oil collection

Used oil is the most prevalent waste product that is routinely handled and disposed of in marinas. Depending on the fleet mix, the amount of oil generated can be staggering. A typical Alaska purse seiner will change oil after each fishing opening and leave up to 12 gallons behind. If you have 50 of these vessels operating in your facility, the used oil accumulated from 50 vessels can reach 2,400 gallons in a month. Many charter fishing vessels also generate large amounts of used oil.

Most harbors are forced into some form of used oil collection. The biggest reason is purely self-defense. If adequate disposal facilities are not available at a harbor, used oil will end up in the water. Containers of used oil will begin to appear at trash receptacles and secluded points throughout your facility.

Used oil must be protected from contamination with other substances. This includes gasoline, antifreeze, water, and solvents. The most effective method of preventing contamination of this waste stream is to require controlled access to the dump location. Users should be asked about the oil they intend to dump and a facility employee should inspect the containers brought to the disposal site.

If used oil is not contaminated it can be added to heavy equipment fuel, burned as a heating fuel, or reconditioned and reused as motor oil. But if it is contaminated with brake cleaner or solvent, for example, it is a hazardous waste and could cost \$1,000 a drum to dispose of. Oil that is contaminated must be shipped in special containers, transported by a licensed handler, and disposed of at an approved facility. The Environmental Protection Agency (EPA) has a “no dilution” regulation that could require an entire tank full of used oil to be treated as hazardous waste if it becomes contaminated. The cost of this handling and disposal could cripple a harbor’s budget.

David Nyman, P.E., of Restoration Science and Engineering provided some recommended practices for harbors that collect used oil.

- Maintain collection and storage facilities free of leaks and spills or residue.
- Equip all storage facilities with lids or coverings to prevent water intrusion.
- Conduct regular inspection and maintenance of used oil collection containers.
- Comply with local fire codes, and state and federal safety regulations.
- Label storage tanks “Used Oil.”
- Clean up any used oil spills or leaks immediately and keep cleanup material on hand.
- Report all spills to regulatory agencies.
- Establish generator profiles and maintain records of used oil test results, filtered water tests, and related used oil compliance records. Keep records for at least three years.
- Maintain “used oil collection and transfer” logs and keep records for at least three years.

- Provide information to the public regarding proper oil management and waste segregation practices.

Another important consideration for ports and harbors is recent regulation by the EPA requiring development of a Spill Prevention Control and Countermeasure Plan (SPCC). The plan covers steps that your harbor will take to prevent the release of oil and what will be done in the event of a spill. An SPCC must be developed through the joint efforts of the facility's management and a registered engineer. Typical plans cover description of collection facilities, spill prevention measures, response resources, response procedures, and future plans for the reception facilities.

Solid and liquid waste materials

Harbors routinely accumulate other waste products during the course of collecting used oil. Users have been known to willfully abandon these waste products at a harbor collection point. Products can include the following items.

- Used fishing line, fishing nets, and plastics.
- Hull scraping and sanding products.
- Scrap materials generated by vessel maintenance.
- Fuel- and oil-contaminated bilge waters.
- Liquid and aerosol paints (especially antifouling bottom paints).
- Lead-acid batteries.
- Fish waste.
- Trash and garbage.

Most of these materials can be readily identified by their label or appearance. Consistent with local and state regulations, harbors can typically accumulate small amounts of these materials for later proper disposal at an approved waste transfer facility or arrange for collection through a qualified third party waste disposal contractor. Materials should be carefully separated. Many of these materials can be recycled, such as unused paints and lead-acid batteries. Recycling eliminates the potential high cost of disposing of these products.

Fishing line, fishing nets, and plastics

Used gillnet and fishing line pose a number of problems for harbor operators. These materials do not break down readily in the environment. Nets are bulky and don't compress well when buried in a landfill. Discarded gillnet is a serious hazard to wildlife, such as sea otters, that can become entrapped in the net.



K. BYERS

Convenient receptacles were placed in Kodiak Harbor for the disposal of recyclable solid waste materials. The MARPOL convention prohibits plastic discharge in waters anywhere in the world.

The Port of Newport, Oregon, was one of the first harbors to provide convenient receptacles for the disposal of recyclable solid wastes. This project was funded with a grant from the National Marine Fisheries Service. One item collected was used, unwanted trawl net that could be re-used to produce plastic products such as erosion control fabric and basketball backstops.

Popular response to this program, and additional grants from the Pacific States Marine Fisheries Commission and the Environmental Protection Agency (EPA), expanded this idea to the recycling of commercial fishing gillnets into many harbors including Cordova, Dillingham, Kenai, Naknek, Petersburg, and Wrangell.

Recycling plastic gillnet can be economically viable, if there is adequate support from fishermen and the community. Gillnet needs to be relatively clean of weed and lead lines to allow efficient recycling. One of the chief advantages of recycling gillnet is the preservation of landfill space. Gillnet is bulky and many Alaska communities have limited landfill capacity. New landfill permits are extremely expensive.

Plastic wastes best management practices

- Provide a dedicated container, clearly marked, for the disposal of used gillnets.
- Place the containers in a convenient location away from docks.
- Keep the containers protected from the weather.
- Empty and clean containers regularly.
- Recycle plastics whenever feasible.

Hull scrapings and sanding products

Routine scraping and sanding of vessel hulls generates material that can normally be treated as a solid waste. An important consideration in disposal of paint solids is the presence of lead. Lead was used in older paints and is prohibited from being disposed of in Alaska landfills. Proper collection and testing of hull scraping and sanding products is essential to the operation of any boatyard. Lead contamination can lead to expensive cleanup and remediation efforts that will be borne by the corporate owner of your harbor.

Establishment of a “policies and procedures”



Best management practice dictates that all paint chips, debris, blast grit, etc., from paint removal be collected and disposed of properly.

document detailing how maintenance is conducted in your facility will prevent many potential problems with hazardous waste cleanup. Harbor customers are usually willing to comply with a reasonable set of guidelines, especially if they are readily available and uniformly enforced.

Hull scrapings and sanding products best management practices

- Use of dustless or vacuum sanders to remove paint is encouraged to collect and retain material.
- Place tarps or filter cloth under vessels to collect paint and scraping chips.
- Consider the installation of a permanent maintenance pad built of an impervious material like concrete.
- Paint removal should be done in an enclosed or sheltered structure or in a tarped enclosure to contain airborne debris and dust.
- Avoid paint removal activities on windy days if an enclosed maintenance shelter is not available.
- Use minimal abrasion when cleaning antifouling paints.
- Consider using a reusable blasting medium.
- Work area will be cleaned after each operation is completed or at least at the end of the day.
- Collect all resulting trash, debris, paint chips, fiberglass, blast grit, and residue from paint removal. Dispose of properly.
- This material must not be disposed of in the trash, or construction materials dumpsters, unless tested by an approved laboratory and certified as non-lead based.
- Paint residue and blast grit that tests high in lead must be sealed in drums and shipped to a facility that will accept hazardous waste.
- Prohibit in-water bottom cleaning, hull scraping, and any other process that could remove antifouling paint and introduce it into the water.

Scrap material generated by vessel repairs

Vessel maintenance produces small quantities of scrap materials like wood, metal, plastic, and fiberglass. Unless there is product

being used that is a known hazardous material, scrap materials are treated the same as solid waste from construction or yards. Containers should be provided to separate recyclable materials, if your community has a recycling program.

Scrap material best management practices

- Provide covered trash containers in a convenient location away from the water.
- Provide clearly labeled containers for recyclable materials, if your community has a recycling program. Materials like steel, aluminum, brass, and plastic may be economically recycled and diverted from the waste stream.
- Empty and clean out trash and recycling containers regularly.
- Make recycling containers look different from trash containers.
- Install a screen around trash containers to improve harbor appearance and help prevent trash from blowing away from the containers.
- Provide directional signage to trash and recycling containers. Clearly label trash and recycling containers.

Contaminated fuel or water

Contaminated fuel or water is a common problem in harbors and can be difficult to deal with properly. Oily bilge water that can't be readily treated onshore is often pumped overboard. There are several solutions for dealing with this problem.

Prevention is by far the easiest method of handling contaminated fuel or water. Fuel vents on vessels should be designed to not allow rainwater to enter the fuel tank. The same can be said of fuel caps. Keeping fuel tanks nearly full reduces condensation of water and also improves vessel stability. There is also value in the proper labeling of fuel, hydraulic, and water tanks. I have seen diesel fuel pumped into a water tank and gasoline pumped into a diesel tank. This creates a terrible mess to clean up after the mistake occurs.

Oily bilges can be prevented in several ways as well. Proper maintenance and replacement of filters, tight connections, and adequate surveillance will prevent many leaks into the bilge. Treatment options on a boat include placement of adsorbent socks, crankcase vent filters, and active bilge pump filter systems.

Shoreside reception facilities for used oil and contaminated fuel or water greatly decrease the chance of these products reaching the



K. EYERS

This vacuum trailer is used primarily to remove oily bilge water from boats. It is part of an equipment package donated to port communities in Prince William Sound by the Exxon Valdez Oil Spill Trustees.

water. On-site treatment facilities are not expensive and there are numerous grant opportunities for construction of these facilities. For example, communities in Prince William Sound, Alaska, received funding to construct used oil and bilge water treatment buildings for their harbors. The ability of a harbor to divert these products from the water is a huge factor in how well you relate to regulatory agencies and secure environmental permits for major repairs or expansion.

Liquid and aerosol paints

Care should be taken in the use of antifouling bottom paint on vessels. Antifouling paints are toxic and are meant to suppress the growth of marine organisms. Paint runoff, overspray, and chips can build up in the environment and cause large cleanup bills. The most common biocide agent in use at this time is copper. Technology is providing improvements to bottom paints and there are now products on the market that limit adhesion of marine growth to hulls rather than attempting to poison them.

Liquid and aerosol paint best management practices

- Use of antifouling paints containing the minimum amount of toxin necessary for the expected conditions is strongly recommended.
- Avoid the use of soft ablative paints and use water-based paints where possible.
- Minimize the use of spray-painting equipment on vessels. Use brushes and rollers whenever possible.



When painting, use brushes or rollers whenever possible, rather than spray.

- Tarp or shroud vessels to avoid overspray or runoff of paint onto the ground or into the harbor.
- Designate an area to mix paints, solvents, and reducers.
- Purchase only enough paint to complete the job.
- Allow empty paint cans to dry out completely prior to disposal.

Lead-acid batteries

Lead-acid batteries are found in virtually all harbor vessels. Battery components are toxic and corrosive and can be a fire hazard.

Sulfuric acid will burn skin and eyes on contact. Lead is a well-known health hazard. Lead and sulfuric acid can readily contaminate soils and cause expensive cleanup if improperly handled. Lead-acid batteries are often abandoned and left in our harbors for disposal.

Lead-acid battery best management practices

- Do not dispose of lead-acid batteries with other solid wastes; recycle them.
- Segregate batteries from other materials such as paper, scrap metal, and flammable materials by some form of a physical barrier. This could be a wall, berm, or dike.
- Store batteries on an impervious surface like concrete and regularly inspect storage area for leaks.
- Handle batteries carefully to avoid broken cases and acid spills.
- If a battery is broken, place it in an acid-resistant, sealed container. A plastic 5-gallon bucket is ideal.
- Avoid long-term storage of lead-acid batteries.
- Store batteries in an upright position, protected from the weather.
- Limit accumulation of batteries. Arrange transportation to a recycler on a regular basis.
- Never drain or break battery cases.
- Don't stack batteries directly on top of each other. Place plywood between layers of batteries.

Fish waste

The concentration of large amounts of fish waste deposited in a small area can cause a huge ugly mess and produce foul odors, increase levels of bacteria, and decrease water quality through reduced oxygen levels. Harbors with much subsistence and/or recreational fishing activity will need to provide some form of a fish cleaning facility.

Options include floating, dock-mounted, and upland facilities. The amount of waste generated will dictate the scale of the facility installed. Seward and Valdez harbors have upland fish cleaning stations with floating waste barges to facilitate disposal. A description of a floating fish waste disposal container used in Valdez, the "humpy dumpster," is in the "Fish cleaning stations" section of this book. The Valdez Harbor floating fish cleaning station, developed



K. BYERS

Users of this upland fish cleaning station clean their fish, and rinse the offal down the trough and into the waste disposal container. The container is towed to deep water and emptied once per day.

in cooperation with Peratrovich, Nottingham & Drage, Inc., is very effective and keeps fish cleaning activities off the dock.

Fish waste best management practices

- Provide adequate fish cleaning facilities in your harbor. These can be varied:
 - A stainless steel sink connected to the sanitary sewer system equipped with a heavy-duty garbage disposal for extremely small amounts of fish waste.
 - A fish cleaning table equipped with plastic or galvanized steel waste containers that can be emptied each day.
 - A fish cleaning table or station equipped with floating waste containers that can be towed to open, deep water.
- Consider composting fish wastes. Minnesota Sea Grant has developed an inexpensive system that may be worth investigating (see Halbach and Baker in References).
- Encourage vessel operators to clean their catch prior to entering the harbor.

- Discourage disposal of fish waste in areas where cleaning facilities are not available.
- Provide directional signage to designated fish cleaning areas.

Trash and garbage

Harbor activities generate large amounts of trash and garbage. Consistent with MARPOL regulations (International Convention for the Prevention of Pollution from Ships), harbors should be collecting trash and garbage from their regular customers. Improper disposal of garbage is a hazard to human health and the environment. Improperly handled trash and litter are an eyesore and reflect poorly on the management of your facility. Trash containers at strategic locations in your harbor will reduce littering. If your community has a viable recycling program, consider installation of recycling containers.

Trash and garbage best management practices

- Place trash containers in convenient locations away from the water.
- Provide clearly marked containers for recyclables if feasible in your community.
- Educate customers on the need to separate potential hazardous waste from ordinary trash or garbage. Examples include used oil, antifreeze, and batteries.
- Empty and dispose of trash regularly.
- Provide directional signs to trash containers and clearly label recycling containers.
- Place a windscreen around trash containers. This will improve your facility's appearance and help prevent trash from blowing away from the container.

Hazardous materials training

Your harbor employees need to be informed of used oil and hazardous waste management procedures in your facility. This training can be both in the classroom and on the job. Dealing with the various regulatory agencies demands that you maintain good records of your employees' training. Keep copies of training certifications in your fire safety or employee safety plans. These are some of the safety programs you should consider.

- Hazardous painting.
- Hazards Communication Standards (worker right-to-know).
- Occupational Safety and Health Administration (OSHA) respirator regulations.
- Hazardous Waste Operations and Emergency Response (HAZWOPER) training requirements.
- Hazardous Materials Awareness and Transportation regulations.
- Local Emergency Planning Committee (LEPC) and Community Right to Know regulations.

Most states have very proactive occupational health and safety departments. The Alaska Department of Labor and Workforce Development (Division of Labor Standards and Safety, Occupational Safety and Health) will conduct preventive on-site facility safety inspections, training for employees, and review of facility safety plans. The site visit identifies potential problems and offers solutions for their correction. Awareness of employee and facility safety can be greatly increased.

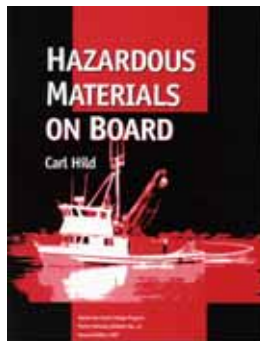

This book, published by Alaska Sea Grant, is useful for boaters and harbormasters. (see references.)

6

Marine structures

Mooring docks

Mooring docks can be found in several different configurations. These include both floating and fixed docks.

Wood floating docks

Wood (timber) floating docks can be expected to last between 20 and 40 years. Life expectancy varies according to the local climate conditions, skill of the contractor, quality of materials used, and adequacy of design. Floats have reached their useful life span when it costs more to repair and maintain them each year than the amortized cost of their replacement.



K. BYERS

Timber floating docks can last 20 to 40 years.

Timber floats are subject to rot, and inspections should focus on likely areas where rot can start. Treated wood has a thin penetration shell of preservative, into the wood's surface, which must remain intact. Rot is likely at any point where the wood surface is disturbed. Mechanical damage, cuts, untreated areas, and bolt-holes can promote rot. Damaged sections should be replaced as they are identified.

Wooden floats are held together with mechanical fasteners that are subject to high stress and wear. Connections between floats, and between floats and pilings, are most likely to fail. Inspections of these areas need to focus on broken or loose bolts, cracked brackets, corrosion, and missing components. Pilings should be checked for excessive wear or chafing with the dock.



Failed dock-to-dock connection.

Bullrails and cleats wear out and are broken after normal use. Broken cleats should be replaced with a similar sized replacement and through-bolted to the dock. Avoid using lag bolts to fasten cleats to a wooden dock. Avoid use of carpeting or rubber mats on the surface of the dock. These coverings hold moisture against the wood and encourage rot. It is also a good idea to prohibit customer-installed equipment on floats. Used tires and fire hose fendering adds weight to the float and shortens its life span. Storage of gear and equipment poses a similar problem. These are items that can be included in your harbor policies and procedures document.

Foam flotation absorbs water over time or can be attacked by petroleum products in the water. Docks that are listing or low in the water should have additional flotation added. Marine life adhering to the bottom of floats can contribute to the overall dead load and will reduce the freeboard of the dock system over time.

Deck surfaces should be pressure-washed and cleaned of organic material every year. Moss and grass are signs that excess moisture is being held against the wood surface and the area will be susceptible to decay. A water-based wood preservative can be applied after the wooden deck has completely dried.

Other areas of interest in maintenance of wooden docks include utility hangers attached to the floats. It is much more common to see water and electrical utilities hung off the outer edge of wooden floats. Brackets need to be secure and in good condition. Marine growth on utility lines can also compound problems with attachment points.

Concrete floating docks

Concrete floating docks can be constructed in several different ways. One method is to build square float modules that have the desired floating dock width on each side. These modules are then connected to each other with treated wood whalers and long through-bolts. The lateral strength of these structures is dependent on the condition of the wooden whalers. A common maintenance concern for this style of float is to ensure the through-bolts are tightened each year and that none of the connecting wood has broken. The monolithic float, another style of concrete dock, is based on float modules that can be more than 50 feet in length. These floats have integrated fastening systems and have very good lateral stability.

Modern concrete floats have a better useful life due to improvements in the manufacturing technology and quality control now in place. Alaska harbors suffered through numerous failures of floats built of lightweight aggregate during the early 1970s. The surface of the concrete dock needs to be kept clean and pressure-washed yearly. A quality concrete sealer should be applied after the surface is thoroughly dried. This will prevent water from entering the concrete surface and freezing, which causes spalling damage. Any damaged concrete surface should be repaired immediately to prevent further damage or corrosion of reinforcement steel.

As in wooden floats, connections between floats and at pilings need to be inspected for failure. Repairs should be made at the time a problem is identified. Utilities on concrete floats are usually less



The longevity of concrete floating docks has greatly improved since the 1970s, due to better manufacturing technology.

trouble than those on wooden docks due to integral utility ducts or chases being built into the float. These chases make it easy to access utilities and also protect them from harm.

Preventing the deterioration of concrete is much easier than trying to repair it later. Concrete floating docks should be thoroughly cleaned every year and treated with a water-based concrete sealer. The deck surface should be inspected for spalling and cracks. Many concrete floats have a surface that is less than 2 inches thick. If you walk a concrete float early in the morning or a few hours after a rain

shower, failed sections can appear as damp areas. Repairs should be made on a timely basis. The longer a crack remains open, the more water will be introduced into the float module. Mechanical fasteners holding the float modules together will need to be tightened annually. Free movement of float modules will contribute to further damage of the concrete surfaces.

Surface repairs of concrete floats can be difficult. Surface patches of spalled areas often pop loose after freezing weather. One method that works well is to use a concrete saw and cut out a section of concrete around the failure point. The surface must be clean of oil, grease, and soil. Avoid the use of solvents to remove petroleum products; their use will force some of the oil farther into the concrete surface. Use a good detergent or trisodium phosphate in combination with a hot-water pressure washer to clean the patch site. The cut edge of the concrete should be coated with a bonding agent—there are two-part epoxy mixes that work well. This technique insures a full depth repair, which resists movement from freezing and captures all the deteriorated concrete.

Another method of repair for modular floats that use wooden whalers is to replace the entire top of the structure. The wooden whalers provide the concrete form and an expansion joint is needed with the adjacent module. Reinforcement wire should be placed in the concrete. This repair will buy you a few more years of service for a failing float system.

Fixed docks

Fixed docks are usually mounted on support pilings and can be used for a variety of purposes. Harbors with water levels that don't fluctuate greatly can use fixed docks for mooring. Another common application is for approach docks leading to harbor gangways or access bridges. Other examples are large docks needed to service cargo and cruise vessels. Piling-based fixed docks have fairly standard components. Support piling is driven into the soil in a grid every 10-20 feet. A heavy timber called a piling cap spans the top of the support piles and provides the foundation for the deck structure above them. Stringers bridge the piling caps and serve much the same purpose as a flooring joist. The stringers provide a framework for attaching the dock's decking. Decking material overlays the stringers and can be concrete or wood. Around the water-side edges of the dock are bullrails or curb blocks that provide basic edge protection and provide a structure to attach mooring lines. The outside face of the dock will have fender piles spaced every 10 to 15 feet that facilitate mooring of vessels. Fender piling holds vessels

off the face of the dock and offers some limited impact protection for the dock. Bulkheads or retaining walls are common along the approach side of the fixed dock from uplands. Bulkheads can be constructed with timbers or steel sheet piling and will be backfilled with soil to provide the transition from the uplands to the dock.

One other common form of dock construction is the sheet pile bulkhead. Sheet piles are heavy steel panels that are driven into the soil and interlock with the adjacently installed panels. A sheet piling can be formed into a straight line and use ties anchored back into the upland for support.

In the open cell bulkhead system, sheet piles are driven in a repeating semicircular pattern that is self supporting. The piles are backfilled with soil and provide a surface for desired operations near the water. These docks are also called hardface docks in some locations.

Successful maintenance of docks relies on the same tools developed for other harbor or port facilities. Recordkeeping, periodic inspections, and immediate repair of damaged sections will markedly increase the useful life span of a dock. Harbor management should consider having an employee on site for the landings of larger vessels at fixed docks. Fender piles are easily



A. SORUM

Large wooden fixed dock in Valdez, Alaska, used to service cargo, state ferry, and cruise vessels.



A. SORLUM

Open-cell sheet piling with attached tidal grid and dock cranes, in Valdez, Alaska.

broken and an operator responsible for a hasty landing will seldom confess to damaging a dock.

Anchor pilings

Anchor pilings are also referred to as cantilever piles. Pilings gain their strength and usefulness from being driven into and supported by soil. A piling must be driven to a critical depth that will support sufficient lateral loads for it to be useful. Load capacity of a piling is the factor of pile material strength and soil characteristics. Regardless of the material used for pilings, they must be installed perfectly vertical to prevent excessive binding or chafing. The three most common materials used for pilings are wood, steel, and concrete.

Wood pilings are very common in part because of their relatively low price and flexibility in use. Wood offers several advantages as piling material. Piling length is easily adjusted with simple carpentry skills of splicing or cutting. Timber pilings are very flexible and can take high impact loads. In annual inspections of wood pilings, inspectors should look for damage caused by marine borers, splits, large cracks, and proper embedment.

Steel pilings are much stronger and more expensive than wood. In the right soil conditions and depths, steel pilings will bend rather than be upset or broken. Steel piles are commonly found in two shapes, H and round pipe. H piles are easier to drive in difficult soil conditions. The length of steel piles can be adjusted by welding or cutting. Installed lengths of up to 100 feet are not uncommon. Annual inspections of steel piling should focus on excessive corrosion and wear.

Concrete pilings displace more soil in driving than steel pilings. Length is very difficult to adjust in the field. Concrete pilings can be difficult to handle and place. Annual maintenance includes



Round steel piles, aligned in piling guides. The guide structure needs to accommodate loads imposed by the dock, wind, current, and moored vessels.

inspection for spalling, cracks, and breaks in the concrete surface.

An important consideration is the interface between the piling and floating dock. Piling hoops or guides need to be designed to match the material and load imposed by the piling. In addition the hoop connection to the dock needs to accommodate the loads imposed by the dock itself, wind, current, and moored vessels on the dock.

Tidal grids

Tidal grids are very important to boaters in areas lacking good haul-out facilities, for example with extreme tidal ranges. Grids are also very inexpensive to use compared to other options.

A typical grid is attached to a fixed or bulkhead dock. As with other docks, fender piles are spaced about 10 feet apart to allow vessels to safely land on the dock. Timber or timber-capped steel bents are located at the base of the fender piles and provide a resting place for vessels to lie on. Normally designers will slope the bents so at least one section is useable with variance in tides. Tidal grids are built of both timber and steel.

Operation of a grid is quite simple. At high tide a boat rides up on the grid and lands at the dock face. Lines are run out to support the vessel and then the skipper waits for the tide to run out. Work is accomplished while the tide is out. Many grids are arranged to allow vehicles to drive right down to the boats. Once work is finished and the tide comes back in, lines are loosed, and the vessel moves away from the grid.

There are a few pitfalls in the operation of a grid that every harbor manager will deal with at some point in their careers. Keels vary on vessels and operators are not as familiar with their shape as they should be. Bents are spaced at regular intervals, but if the front or back of the keel misses one, things get exciting. Vessels using a grid need to be slightly angled toward the face of the dock as the tide runs out. A common mistake for an inexperienced user is to overlook this principle of physics, causing the boat to fall over as the tide goes out. Every year we have at least one skipper run up on the grid at high tide only to realize that it was one of the highest tides occurring for the next week. Skippers have been known to fall asleep (or get lost at the bar) and fail to tend their vessels properly. There have even been a few that tied lines fast to pilings with disastrous effects. A line secured at high tide will hang the boat or rip out bulwarks and cleats. A line made fast at low tide will hold down the stern and let the boat sink right on the grid.



K. BYERS

Boats on tidal grid in Wrangell, Alaska.

Many older vessels have a knife-shaped keel, which will severely damage the wood of a grid bent. One thing you can do to help your grid user is to install a few depth markers along the grid to provide actual depth readout as the boater approaches the dock. Grids have an engineered load rating per bent (hopefully) that needs to be well advertised.

Maintenance of grids mainly involves keeping the spaces between bents cleaned out, and repairing timber bents or bent covers as they are damaged. Timber bents are typically 12 inch square treated timbers that are 20 feet long. This makes them fairly rare and expensive. A damaged bent timber can sometimes be turned over and provide many more years of service. Bents and catwalks between them become very slippery. It pays to pressure-wash them a few times a year to help prevent falls.

Grids pose a number of environmental concerns. While it is still legal to use them in Alaska, their use has been severely limited in many other states. The buildup of old bottom paints, lead-acid batteries, oil, and discarded zinc anodes from sloppy maintenance can produce the equivalent of a toxic waste dump in a community.

Development of operating procedures and practices is very important for communities with tidal grids. Unregulated use of the grid could even jeopardize future use of the facility. There are creative, effective ways to get vessel work done on a grid while minimizing the impact on the environment. Users need to be educated on the importance of good stewardship. Complacency toward the environment will inevitably lead to more stringent regulation from outside agencies that may not fully understand the harbor industry.

Launch ramps

Launch ramps are a common fixture in harbors and essential to trailered boaters for access to the water. Ramps can be a huge frustration to those who have difficulty backing a trailer and even more so to the next guy in line. Effective operation of launch ramps requires educating users and encouraging adequate preparation prior to nearing the ramp. There are many incidents every year at the ramp that could have been avoided with proper preparation. Rushing at the launch seems to increase as the number of boats in line increases. Users get in a hurry. The drain plugs don't get put in, the boat rolls off the trailer or a hitch comes loose and the whole works goes down the ramp. The instant one of these events occurs you lose use of your ramp for hours. Our harbor published a set of guidelines to help boaters at the launch ramp, Valdez Harbor Launch Ramp Guidelines.

Valdez Harbor Launch Ramp Guidelines

Pre-launching preparations

- Prepare your boat for launching away from the ramp as a courtesy to others and to prevent rushing during the launch.
- Register your boat and pay for the launch at the self-service station.
- Ensure that there has been no damage to the boat caused by the trip to the harbor.
- Raise the lower unit or outboard so that it will not hit bottom during launching.
- Remove trailer tie-downs and make sure that the winch is properly attached to the bow eye and locked in position.
- Put the drain plug in securely.
- Connect the fuel tank, check fluid levels and safety equipment.
- Disconnect the trailer light plug to prevent shorting of electrical system or burning out a bulb.
- Attach a line to the bow and the stern of the boat, so that the boat cannot drift away after launching and it can be easily maneuvered at the courtesy float.
- Visually inspect the launch ramp for hazards such as a steep drop-off, slippery areas, and sharp objects.
- When everything has been double-checked, proceed slowly to the ramp remembering that your boat is just resting on the trailer and attached only at the bow.
- The ideal situation is to have one person in the boat and one observer at the water's edge to help guide the driver of the tow vehicle.

Boat launching

- Drive to the ramp and observe the directional signage.
- Back the boat and trailer down the appropriate ramp.
- Keep the rear wheels of the tow vehicle out of the water. This will generally keep the exhaust pipes out of the water. If the exhaust pipes become immersed in the water, the engine may stall.
- Set the parking brake and insure the transmission is in park.
- Lower the boat motor and prepare to start the engine (after running blowers and checking for fuel leaks).
- Start the boat motor and make sure that water is passing through the engine-cooling system.

- Release the winch and disconnect the winch line from the bow when the boat operator is ready.
- At this point, the boat should launch with a light shove or by backing off the trailer under power.
- Return the towing vehicle and trailer to the parking lot as soon as the boat is launched, so the next person in line may proceed.
- Finish any final loading of your boat at the transient mooring float, away from the launch ramp, so that others may continue to use it.

Boat retrieval

- The steps for removing your boat from the water are basically the reverse of those taken to launch it.
- Keep in mind that the following conditions may have changed since you launched your boat:
 - Change in wind direction and/or speed.
 - Change in current and/or tide.
 - Increase in boating traffic.
 - Visibility.
- Unload the boat away from the launch ramp.
- Maneuver the boat carefully to the submerged trailer, and raise the lower unit of the boat engine.
- Winch the boat onto the trailer and secure it.
- Drive the trailer with the boat aboard carefully out of the ramp to the washdown area for cleanup, reloading, and an equipment safety check.
- Remove the drain plug to allow water to drain from the bilge.

Launch ramp maintenance involves many of the same skills developed for care of floating dock. Most ramps have courtesy floats to facilitate movement of boats. Inspect for wear, and repair as needed. Trips and falls are more common on these floats because of the angle they assume with the ramp. The surfaces of most ramps serving salt water are built of pre-stressed concrete planks pinned to wooden sleepers. Depressions can form at the edges and ends of the planks that will allow a boat trailer to fall off the plank. Fill can be brought in to correct this problem. Many ramps are at the ends of harbors and attract floating debris. The ramp needs to be checked regularly for logs and debris that will interfere with launching or hang up under the courtesy floats.



Boat launching the hard way! With some education in launch ramp guidelines, your harbor users will avoid embarrassing incidents like this one.

Breakwaters

Breakwaters can be found in four basic configurations. They include rubble-mound construction, solid vertical walls, wave boards or fences, and floating wave attenuators. Many harbor projects combine these construction styles.

A major concern in mooring basin design is water circulation or flushing of the harbor. A number of controversies exist concerning this subject. Adequate flushing is dependent on aspect ratio (length vs. width), depth, entrance channel shape of the basin, the tidal prism, and the ability of water to move through installed breakwaters. The services of a highly qualified coastal engineer and the use of modeling is recommended as part of any new harbor construction design.

Rubble-mound breakwaters

Rubble-mound breakwaters are typically constructed with a core of sand, gravel, or quarry-run stone that is formed by dumping the material on the seabed to form a mound. The core may be protected by filter cloth to prevent the finer particles of material from washing out. This mound is then covered with large, irregular rocks that can

weigh up to 90 tons, called rubble. The rubble used in this form of breakwater is also known as riprap and its purpose is to protect the mound from erosion caused by currents and waves. Larger rock is needed when there is greater attack by waves. Pre-cast concrete armor units can also be used in locations lacking adequate quarry sites.

Damage that can occur to a rubble-mound breakwater includes sloughing of the riprap, erosion, or sinking of the base material and actual damage to the structure caused by overtopping or severe waves. Inspections should be made of rubble-mound structures on a periodic basis, maybe once a year or after severe events like storms or earthquakes. Look for sloughing and excessive gaps in the riprap, especially at low tide. Areas of particular interest may also be inspected by boat or diver.

Rubble-mound breakwaters are simple, robust structures that should have useful lifetimes of over 30 years depending on the exposure. Repairs made immediately after damage is noticed will greatly increase the structure's useful life. These structures suffer few catastrophic failures. For example, in a collision by a vessel, damage would be minimal to the breakwater and repairs much less problematic compared to a steel or wooden structure.

Permeable wave barriers

Permeable wave barriers (PWB), structures built primarily out of galvanized steel, are a type of solid vertical wall breakwater. They are typically the size of a dock, built to withstand the same waves and vessel sizes. In many cases a PWB can also be designed for use as a dock structure, which will allow for additional moorage of vessels in a harbor.

One configuration is the use of a round steel piling with a section of sheet piling welded along its length on two sides 180 degrees from each other. The sheet pile is interlocked with the next adjacent piling to form a vertical barrier to the prevailing waves. The bottom edge of the attached sheet piling is left short of the seafloor to allow the free movement of water through the structure.

PWB structures offer several benefits to any harbor considering their use. These are flexibility in design, and resistance to seismic damage and environmental impacts.

Flexibility in design

Permeable wave barriers utilize vertical faces, which maximize the usable space within a mooring basin. Rubble-mound breakwaters have 2:1 side slopes, which can take up considerable space in a



PND

A sheet pile wave barrier, showing round steel piling with a section of sheet piling welded along its length on two sides, in Blaine, Washington.



PND

A sheet pile wave barrier forms a vertical barrier to the prevailing waves.

Cost of Rubble-Mound Breakwater and Permeable Wave Barrier vs Seafloor Elevation – Source PND

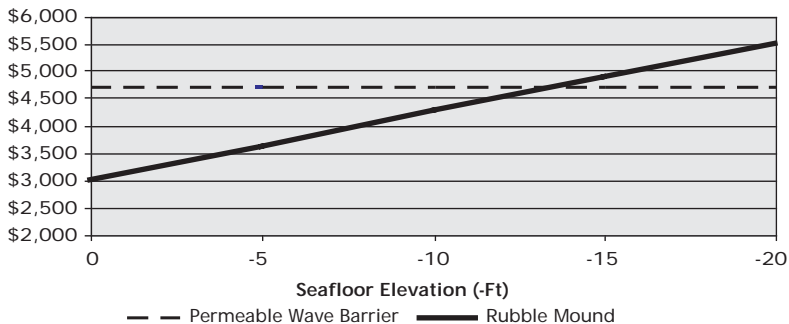

harbor. PWBs can be built to accommodate moorage of large ships on the inside or outside face of the barrier. Permeable wave barriers can be built to accommodate recreational fishing piers and support structures for sport fisheries.

Permeable wave barriers can be constructed in deep waters at a lower cost than rubble-mound breakwaters. Seafloor elevation of -60 feet mean lower low water (MLLW) has been identified as the maximum practical depth for constructing a permeable wave barrier. A permeable wave barrier would cost about \$4,700 per linear foot at this depth. The cost of permeable wave barriers and rubble-mound breakwaters are comparable at a depth of -15 feet MLLW. Permeable wave barriers are not practical for depths less than -10 feet MLLW because of the need to allow sufficient space between the bottom of the structure and seabed for circulation of water.

Permeable wave barriers can be constructed in deep waters at a lower cost than rubble mound breakwaters.

Permeable wave barriers are much easier to remove compared to a rubble-mound structure. This is an important consideration for construction impacts on future expansion projects. PWBs are also much easier to modify or extend than rubble-mounds breakwaters.

Resistance to seismic damage

Resistance to earthquake damage is an important planning concern for harbors in Alaska and in other areas along the Pacific Rim. Permeable wave barriers are likely to suffer less damage during earthquakes than rubble-mound structures, especially on steep submarine slopes. Rubble-mound structures can impose huge loads

to submarine soils. Permeable wave barriers also have less mass and generate less kinetic energy in a seismic event.



The 1964 Alaska earthquake caused multiple tsunamis to hit Seward (above) and other coastal towns, wiping out small boat harbors in Kodiak, Valdez, Seward, and Whittier, among others. The Seward small boat harbor was obliterated by a combination of displacement of ground from the earthquake and several tsunamis that washed back and forth, like water in a bathtub, in Resurrection Bay over a period of hours through the night.

Environmental impacts

Permeable wave barrier technology can promote better harbor flushing than rubble-mound breakwaters in some situations. Water can readily move through the barrier, which could increase harbor flushing and improve overall water quality. Fish and other wildlife are free to move through the wave barrier structure as well. This is an important consideration for proposed harbors in areas with native migratory fish populations.

Rubble-mound structures cover substantial areas on the seabed floor with rock, which displaces existing habitat areas. The ability to use PWBs in deeper water also lessens the impact of construction in the intertidal zone due to the reduced need for dredging. PWB structures do not require development of a rock quarry and the associated hauling activity during construction.

Floating breakwaters

Floating breakwaters are floating structures tethered to anchors on the seabed designed to dissipate wave energy. There are various types, including box, pontoon, and mats. A typical floating breakwater is a foam-filled concrete float, similar to those used as floating dock in a harbor, but much more robust and heavy. Floating breakwaters act much like a moored barge in deflecting waves.

Advantages of floating breakwaters include use in deeper water, simple construction, and effectiveness for moderate wave conditions. These structures are also used in some facilities for walkways, mooring locations, or fishing piers. Floating breakwaters can be useful for protecting moorages that might require a secondary breakwater.

Maintenance is similar to the floating docks found in the harbor. Floating breakwaters are subject to greater exposure and need closer periodic inspections. Failure of module connection hardware is a major problem. A properly engineered structure should have a complete operation and maintenance manual that will recommend inspection intervals and areas of concern. Another consideration is movement of mooring anchors. While I was harbormaster in Whittier, Alaska, we had a floating breakwater protecting the harbor entrance that had a habit of moving out to sea and had to be reset from time to time.

Fish cleaning stations

Upland fish cleaning stations

Fish cleaning stations located on harbor uplands are very popular and offer easy access to many users. These facilities provide a sanitary, sheltered location for fish processing and a means to properly collect fish waste. Upland stations are also accessible by users from surrounding areas. Valdez harbor has constructed two upland fish cleaning stations, and they are among the most important amenities used by our customers.

Floating fish cleaning stations

Valdez Small Boat Harbor worked with PND to design a floating fish cleaning station. The design came out of demand for more cleaning facilities to support the growing charter fishing industry, and a lack of available floating dock space. The floating stations are built of aluminum and use coated expanded polystyrene flotation.



K. BYERS

Upland fish cleaning station in Seward, Alaska. Upland stations are accessible to many users.



K. BYERS

Upland fish cleaning station in Valdez, Alaska. The upland stations in Valdez are among the most important customer amenities.

Walking surfaces are treated with an arc plasma–deposited anti-skid surface and guardrails protect the edges. There several advantages to using this system, especially moving charter boat cleaning activities off the floating docks and out of the path of other harbor users. Safety is improved—when fish are no longer in contact with the dock, the risk of falls from fish slime is reduced. Space is provided on the floats for ice chests and other gear. The floats are semi-portable, being held in place with lines and having a single water pipe connection. The cleaning station is U-shaped and has room for five people to work. Each workstation has an ultra-high molecular weight polyethylene (UHMW) cutting surface and spray wand.



K. BYERS



K. BYERS

Above—Floating fish cleaning station with removable fish waste disposal container. Photo on left shows durable polyethylene cutting surface and spray wands.

A “humpy dumpster,” a floating fish waste disposal container, fits inside the “U” and the work surfaces are shaped to funnel waste into the container. Humpy dumpsters are named after Alaska pink, or humpy, salmon. They are aluminum cages with integrated floats and swinging gates that allow fish waste to be dumped from the container in another location. We currently have nine of these receptacles in the harbor, and we tow them out to deep water to empty the fish offal on a daily basis.

Gangways

Gangways or bridges are needed to provide access from harbor uplands to mooring facilities. The length of the gangway varies directly with the tidal range of the harbor. An inland lake with constant water levels does not require much gangway to reach the docks. Extreme tidal ranges in Alaska harbors can exceed 25 vertical feet. A gangway that can accommodate this tidal range, as well as the new Americans with Disabilities Act requirements (see Appendix A), would be a minimum of 80 feet long.

Gangways are built just like bridges and have similar components. The sides of the gangway have a top and bottom cord with integral web members running diagonally from the top to the bottom. The gangway has a series of stringers that allow fastening of deck material. Many gangways have a cover to shield the walking surface from rain and snow. The bottom edge of the gangway rides in a set of tracks mounted on a separate landing float. The top of the gangway is attached to the approach dock or bulkhead with a heavy-duty set of hinges. The openings at each end of the ramp are covered with transition plates.

Operational gangways pose a number of concerns for a harbor operator. Slips, trips, and falls constitute the large majority of personal injury claims made against harbors. Harbors attract people who are not familiar with walking on gangways. Or a tenant may be in a hurry and may fall on your gangway. There must be good handrails on both sides of the ramp. Transition plates need to ride freely at the end of the gangway and should be coated with nonskid material. The deck surface needs to be covered with a nonskid material. We have had good experience with indoor/outdoor carpeting. One side of the gangway should have cleats or bars installed across it to provide a walking surface when there is snow or ice on the deck surface. On one of our covered gangways we installed full-length side curtain of heavy-duty vinyl, with clear panels for better lighting, attached to the gangway sides with

lashings of nylon line. It has been remarkably effective at preventing the buildup of snow and ice. This is especially significant because Valdez receives more snow than any other city in Alaska, often more than 30 feet per year.

Most gangways utilize a skid/runner arrangement riding in a set of angled iron tracks to allow movement of the ramp with the tide. The end of the gangway may use a plastic pad or wheel to reduce friction in the track. Check for free movement of wheels and condition of plastic friction pads, during your harbor maintenance inspection. The tracks the gangway rides in can be fouled by ice or snow and the runners can jump out of the tracks. Pumping salt water onto the landing float will remove the ice buildup. Gangways typically land on a special float attached to the rest of the dock. This float should be checked for adequate freeboard and attachment to the main floating dock.

Gangways are the natural path for extension of utilities into the harbor. Pumpout, water, fire-fighting, electrical, television, and telephone service lines can all be attached beneath the gangway deck. Gangways move constantly through the day and service connections will work loose over time. Utilities can be effectively inspected with the harbor skiff at low tide.



K. BYERS

The cover on this gangway shields the walking surface from rain and snow.

7

Marine construction materials

Wood

Wood offers a number of advantages in the construction of marine facilities. Wood is strong, lightweight, and readily available. Wooden structures offer greater strength in tension and are forgiving of shock loads. Wood will provide a useful life of more than 30 years with little maintenance and can last twice as long when properly cared for. Douglas fir is the predominate species of wood used in Alaska.



K. BYERS

This stack of Douglas fir boards has been treated with ACZA at a preservative retention of 0.6 pounds per cubic foot of wood.

Literature suggests that at least 10% of the wood cut each year goes to replace decayed wood. This doesn't include replacement costs or loss of use. The four principal maintenance concerns for wood include identification of principal organisms of decay, treatments made to prevent decay, decay prevention strategies, and inspection methods to locate wood decay in harbor facilities. Practical methods of repair are discussed in detail elsewhere in this book.

Wood damage by organisms

The principal organisms that can degrade wood are bacteria, fungi, insects, and marine borers.

Bacteria

Normally bacteria do little damage to wood, but can cause it to absorb or retain excessive moisture. High moisture content can reduce wood strength and, more important, provide ideal conditions for the growth of decay fungi. Bacteria also can attack wood cell structures and wood preservatives, which can condition the wood for infestations of fungi.

Fungi

Decay fungi cause most of the damage to wooden marine structures in the Great Lakes region and in most freshwater lakes. Fungi are microscopic, threadlike organisms that derive nourishment from organic matter. They do not produce chlorophyll. A number of species need wood for their existence. Growth of fungi is governed by temperature, moisture content, and oxygen level. Fungal spores are found everywhere and will germinate as soon as a suitable environment is present. One particular problem with controlling fungi is that they penetrate the wood cell wall structures where they can be difficult to control. Most wood preservatives are absorbed only into the wood intercellular space and not into the wood cell itself.

There are four general groups of fungi: mold, sap stain fungi, decay fungi, and soft-rot fungi. Mold is visible on the surface of wood and is easily removed from it by brushing or washing it away. It may appear as a powdery or fuzzy growth and can have a wide range of coloration. Sap stain fungi penetrate into the sapwood and produce a typically blue stain that cannot be removed from the wood surface. Mold and sap stain fungi are of little concern in wood decay, but are an important indicator that conditions are perfect for infestation of the wood by other, more harmful fungi and bacteria. These fungi also have some impact on the shock resistance of the infected wood.

Decay fungi cause two distinct presentations in wood: brown or dry rot and white rot. Brown rot is characterized by removal of wood cellulose; the wood turns a brown color, shrinks and collapses, and cracks across its own grain. White rot is characterized by the loss of both cellulose and lignin; the wood turns white on its surface and does not shrink or collapse until the wood has been severely decayed.

Soft-rot fungi are less common and can tolerate wider moisture conditions than decay rots. This fungus favors conditions of alternating wet and dry cycles. A soft-rot fungus normally penetrates wood at a more shallow depth and the underlying wood will be relatively undamaged. This type of rot poses the greatest risk to thin materials like slats and siding. Soft-rot is responsible for many cases of surface weathering.

Insects

Beetles

Beetles that pose a problem for harbors derive their nourishment from the wood itself. These beetles typically fall into two groups: powder-post beetles and flat-headed borers.

There are three primary groups of powder-post beetles—Lyctidae or true powder-post beetles, Bostrichidae or false powder-post beetles, and Anobiidae or deathwatch beetles. These beetles are $\frac{1}{8}$ to $\frac{1}{4}$ inch in length and dark brown to black in color. Lyctidae and Bostrichidae beetles prefer dry, seasoned hardwood, while Anobiidae beetles tend to inhabit damp wood found in coastal regions. These beetles are found throughout the Western and Midwestern United States. Adult beetles lay eggs in exposed fissures and the beetles spend most of their lives as grubs within the wood. The first sign that there is a problem will be the presence of fine wood powder being ejected from very small exit holes. While there are cases where these beetles have caused substantial damage to wooden structures, the main concern should focus on the holes made by the beetles' boring where fungi rot can do further damage.

Flat-head borers tend to prefer unseasoned wood to lay eggs. On the West Coast the flat-head species *Buprestis aurulenta* especially targets Douglas fir. The beetles range from $\frac{1}{3}$ to $1\frac{2}{3}$ inches in length and can have bright metallic coloring. Flat-head borer damage resembles that caused by powder-post beetles. These beetles, associated with trees damaged by fire or drought, are not seen as major threats to wooden marine structures. But the presence of flat-head borers in a wooden structure is an indication of other substantial structural problems.

Management of wood-boring beetles begins with preventing infestation via exposed cracks or fissures with the use of wood preservatives. Severely damaged sections of timber need to be replaced to maintain structural soundness. Larger holes and cracks should be filled and repaired. The repaired wood surfaces and areas where exit holes are present should be coated with a wood preservative, stain, or paint to prevent reinfestation by the beetles. Wood that is kept damp will be vulnerable to beetles and further attack by fungi. Moisture needs to be controlled before any other action can be taken against beetles. A licensed exterminator can apply an insecticide like chlorpyrifos to control the beetles.

Termites

Termites are well known for destroying wood. They are often confused with carpenter ants, but there are several differences. The antennae of ants are elbowed, with a bent appearance; termites have straight antennae. The waist of an ant between its thorax and abdomen is very narrow, while a termite has a thick waist. The wings of an ant are longer in the front than the back; termites have two equal-size pairs of wings. Flying ants are likely fire ants or carpenter ants. Ants have strongly attached wings and are good fliers. Termite wings are weakly attached and they are shed soon after swarming, which facilitates movement. If you encounter a pile of discarded wings in some sheltered location, they are likely from a recent swarm of termites.

Termites are in two broad groups—those that live only in wood and those that are able to burrow in the ground and move from one source of wood to another. Wood-inhabiting termite colonies are limited to the single piece of wood they occupy and will die out when the wood supply is exhausted. Wood-inhabiting termites are considered more primitive than the ground-burrowing or subterranean termites.

Subterranean termite nests can be 20 feet below the surface of the earth. These termites move from one source of wood to another by burrowing through the soil. They use mud tubes above the soil surface. Populations of subterranean termites are not limited to a single food source and they can grow to enormous size. Subterranean termites have developed very complicated social structures. These creatures pose a huge risk to wooden structures, especially in regions where the average annual temperature is greater than 50°F. Damage caused by colonies of termites is reduced by the forced inactivity during the winter cold of northern regions.

Subterranean termite society is divided into three distinct castes: reproductive males and females, soldiers, and workers. Winged reproductives are brown to black in color and most commonly seen when the colony swarms. Workers are pale white, blind, and wingless. They perform all of the work and are responsible for the damage caused by the colony. Workers will remain unseen until a portion of the colony or a mud tube is exposed. Soldiers are larger than workers and have elongated heads. There are fewer soldiers than workers and they function to protect the colony from intruders.

Inspection for termites can be made with a pick and flashlight. Areas of concern in a harbor will be where wood is in close proximity to the ground. Areas close to the ground, sheltered from the weather, intersections of posts and timbers, and cracks and expansion joints should be examined for mud tubes and activity by swarming termites. Wooden surfaces can be probed with a pick to detect weak areas and the presence of termites. Harbor structures that merit special attention are wooden bulkheads of approach docks, piling not normally submerged in water, boardwalks, and wooden retaining walls.

Management of infested areas includes removal of the damaged wood and repair of structural members. Infested wood surfaces can also provide a ready avenue to fungi rot. Treated lumber is resistant to infestation and should be used in the repairs. Care needs to be taken to avoid contact of lumber with the soil, and control of moisture is important as well. Sheet metal barriers can be effective in preventing movement of termites from concrete or masonry to wood by blocking the construction of mud tubes. A professional exterminator can apply a chemical barrier in the soil around a particular structure.

Carpenter ants

Carpenter ants are $\frac{1}{4}$ to $\frac{1}{2}$ inch in length and are normally black in color. Workers are wingless and reproductive members of the colony have wings. Colonies capable of producing reproductive individuals are six to ten years old and have 2,000 members. Carpenter ants enter wood through cracks or fissures and attack where there is excessive moisture. They prefer wood that is already softened by moisture or decay.

Signs of infestation by ants include coarse sawdust visible lying alongside timbers and the movement of workers into the nest. Damage is caused by ants chewing wood into small particles during the process of building tunnels or galleries. Ants tunnel into the softer parts of the wood parallel to the grain. Carpenter ants do not

consume wood, but use it as shelter. Tunnels can cause structural damage and accelerate rot by exposing more of the wood's interior to moisture. The most damage from ants occurs in the warmer summer months.

Carpenter ants can be controlled by the use of insecticides, but the best method of control is to physically remove the nest and any damaged wood associated with it. Once the nest is removed, steps should be taken to resolve the moisture problems that promoted the original infestation. Control measures included preventing water from being trapped and sealing obvious cracks, crevices, and damage found on wood surfaces.

Carpenter bees

Carpenter bees, *Xylocopa virginica*, are large bees that resemble bumblebees and occur throughout Alaska. These can be up to 1½ inches long and typically are metallic blue in color with green or purple highlights.

Carpenter bees, like carpenter ants, excavate tunnels in wood for nests and shelter. Unlike termites, carpenter bees do not consume wood fiber; they only displace it for nesting sites. Nests are cut into the wood by both male and female bees. The entrance hole is perfectly symmetrical and ½ inch in diameter. Sawdust from excavating tunnels is often seen on the ground below the nesting site. After boring the entrance tunnel, bees remove wood parallel to the surface. Individual cells are constructed for the developing larvae and food storage. Adult bees will overwinter in the tunnels and produce one generation of bees a year.

Carpenter bees will attack most wood surfaces, with hardwoods being less vulnerable to attack. Painted and treated surfaces are not immune to attack. Most damage caused by the bees is minor and will have little structural impact to harbor infrastructure. Damaged areas do provide an avenue to moisture and fungi rot. Woodpeckers in search of bee larvae can also further the initial damage caused by the bees.

Management of carpenter bees can include treatment by a qualified exterminator. Chlorpyrifos, permethrin, and carbaryl are effective, but they may contaminate runoff water. Drying agents, such as boric acid and diatomaceous earth, can be effective and pose little risk to the environment. Treatment with pesticides will require multiple applications to control carpenter bees. Entrance holes can be plugged with steel wool after bees have left the nests. Damaged areas should be coated with wood preservative, paint,

varnish, or stain. Structural members should be replaced if extensive damage has occurred.

Marine borers

Several species of marine borers can be found in the coastal waters of North America. Marine borers have been a well known threat to wooden ships for over 2,000 years and can cause substantial damage to submerged portions of treated and untreated wooden structures. Damage is less severe in the northern latitudes than in the south. Rate of attack is directly related to water temperature, salinity, presence of pollutants, and borer species. These creatures can be roughly divided into two groups: mollusks and crustaceans. Mollusks include shipworms (*Teredo* and *Bankia*) and pholads (*Martesia*). Crustaceans include gribbles (*Limnoria*) and pillbugs (*Sphaeroma*).

Shipworms are not worms, but are closely related to clams or oysters. Shipworms cause substantial damage to the interior spaces of a wooden timber, yet present little visible damage to the surface. The only apparent damage will be tiny entry holes in the wood's surface. The photograph showing shipworm damage is a cross section of a hull plank taken from a fishing vessel that was in service in Southeast Alaska. The surface is undamaged, but the center is riddled with $\frac{1}{2}$ inch diameter holes and the hull plank is only $1\frac{1}{2}$ inch thick.



Shipworm damage to a section of a Southeast Alaska vessel hull. Tunnels are $\frac{1}{2}$ inch in diameter.

Shipworms have shell structures at their heads, a worm-like body, and a tail composed of a pallet and siphons. Shipworm larvae attack vulnerable sections of wood and scrape small holes into

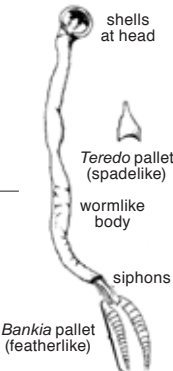
Popular and generic names	Appearance	Geographical distribution	Wood-damage characteristics
Shipworms <i>Teredo</i> <i>navalis</i> Linné	Adults can grow 1 to 2 feet (30.5 to 70 cm) long; ½ inch (12 mm) diameter.	Warm seawater, San Francisco Bay and south, but also in some British Columbia localities. Can withstand lowest salinity of all borers, reportedly as low as 5 parts per 1000 (seawater is 30 to 35 parts per 1000).	 <p data-bbox="809 370 923 751">Usually, little external evidence can be found to indicate shipworm attack. Entrance holes remain ⅙ inch (1.5 mm) or less in diameter while this clam's body enlarges as it enlarges its burrow.</p>
<i>Bankia</i> <i>setacea</i> Tryon	 <p data-bbox="291 797 437 909">Adults can grow 5 to 6 feet (1.5 to 1.8 m) long; ⅞ inch (22 mm) diameter.</p>	The major shipworm north of San Francisco. Much more sensitive to salinity changes than <i>Teredo</i> , so many northern estuaries are free of shipworm attack in their upper reaches.	

To detect presence:

1. Sounding devices used by divers can detect damage in 25% increments.
2. Immerse untreated wood test panels and cut up at monthly intervals to see if borers are present. Remember: wood floats, so attach a sinker.

To prevent attack:

1. 20 to 25 lbs of marine-grade creosote or creosote-coal tar per cubic foot of wood.
or
2. 2.5 lbs of ACA or CCA per cubic foot of wood.

To stop attack:

1. Wrap pile with plastic well below mud line to above tidal range to kill existing borers, by eliminating their oxygen supply, and prevent others from attacking.
or
2. Reinforce pile with a concrete jacket.

The major marine borers: description, damage, and treatment (Source: Morris et al. 1984).

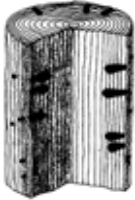
Popular and generic names	Appearance	Geographical distribution	Wood-damage characteristics
Pholads <i>Martesia striata</i> Linné	2 to 2½ inches (50 to 63 mm) long; 1 inch (25.4 mm) diameter 	Inhabits tropical waters; a severe problem in both untreated and inadequately treated wood in Hawaii and off the Mexican coastline. They also burrow into rock.	 Unlike the shipworm's, the size of the entrance hole increases to about ¼ inch (6 mm), making it possible to notice their presence.

To detect presence:

1. Look for entrance holes.
2. Sounding devices used by divers can detect damage before the item is destroyed.

To prevent attack:

1. 20 to 25 lbs of marine-grade creosote or creosote-coal tar per cubic foot of wood or
2. Dual treatment.

To stop attack:

1. Wrap pile with plastic well below mud line to above tidal range to kill existing borers, by eliminating their oxygen supply, and prevent others from attacking.
or
2. Reinforce pile with a concrete jacket.

its surface. As the shipworm grows, it rasps away wood to form a tunnel and can grow to several feet in length. The original entrance hole provides access to the water for the shipworm via the pallets and siphons. The siphons provide fresh water to the shipworm and passage of wastes. The pallets are protective structures that can block the entry hole if the creature becomes threatened by outside disturbances or water pollution. Based on the very small entry hole ($\frac{1}{16}$ inch diameter) and the chance it may also be blocked by the pallets, infestation of a piling by shipworms can be difficult to detect.

Teredo navalis shipworms are found in the warmer waters south of San Francisco Bay. They are tolerant of greater salinity ranges than *Bankia* and can survive farther up river estuaries. *Teredo* shipworms can reach one to two feet in length and $\frac{1}{2}$ inch in diameter. *Bankia setacea* shipworms occur along the entire west coast of North America and cannot tolerate salinity of less than

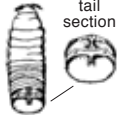
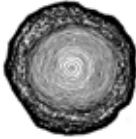
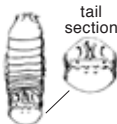
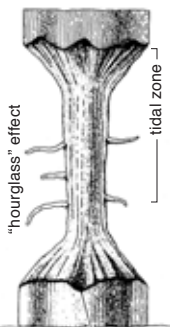
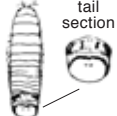
Popular and generic names	Appearance	Geographical distribution	Wood-damage characteristics
Gribbles <i>Limnoria lignorum</i> (Rathke)	⅓ to ¼ (3 to 6 mm) long; no tubercles. 	Found principally in cold waters of North America, generally north of San Francisco Bay	 Attacks untreated wood ⅓ to ¼ inch (6 to 12 mm) deep burrows
<i>Limnoria quadripunctata</i> Holthius	⅓ to ¼ inch (3 to 6 mm) long; 4 tubercles. 	Inhabits temperate water.	 Attacks untreated wood "hourglass" effect tidal zone mud line
<i>Limnoria tripunctata</i> Menzies	⅓ to ¼ inch (3 to 6 mm) long; 3 tubercles. 	Present as far north as the Strait of Georgia. Attack on creosoted wood is prevalent from San Francisco Bay south.	Attacks untreated and creosoted wood

Drawings by Donna Klentz

To detect presence:

At low tide, check wood for thinning, accompanied by a network of interlacing tunnels, each ⅓ inch (4 mm) in diameter, usually not deeper than ½ inch (12 mm).

To prevent attack:

Where attack of creosoted wood is not prevalent: 20 to 25 lbs of marine-grade creosote or creosote-coal tar per cubic foot of wood or 2.5 lbs of ACA or CCA per cubic foot of wood. Where attack of creosoted wood is prevalent: Dual treatment or 2.5 lbs of ACA or CCA per cubic of wood.

To stop attack:

1. Wrap pile with plastic well below mud line to above tidal range to kill existing borers by eliminating their oxygen supply, and prevent others from attacking.
or
2. Reinforce pile with a concrete jacket.

20 parts per thousand. They grow up to six feet in length with a diameter of $\frac{1}{16}$ inch.

Pholads in the genus *Martesia* are rock-burrowing clams that can also attack wood. They are more commonly found in the warmer water of Mexico and Hawaii. Like clams, pholads reside inside of two shell halves and are imprisoned within the wood surface after they enter it. Pholads are pear-shaped and are about 2 inches long. They initially bore a $\frac{1}{4}$ inch diameter hole into the wood surface and grow to 1 inch in diameter. These borers typically do not penetrate the wood surface much deeper than their 2 inch body length. Pholads are easier for divers to identify due to their larger entrance burrows.

Gribbles in the genus *Limnoria* are small ($\frac{1}{8}$ to $\frac{1}{16}$ inch), free-swimming crustaceans that burrow into the surface of wood. They do more damage to marine structures than shipworms. They do not penetrate the surface very far but weaken the wood to the action of tide and surface debris. As the damaged wood is worn away, gribbles continue to burrow deeper for shelter. Piling attacked by gribbles can be reduced in diameter by 1 inch per year and take on an hourglass shape at the active tide line. Gribbles have the ability to move freely to undamaged wood in search of better habitat. One species of interest is *Limnoria tripunctata*, which can attack creosote-treated wood at latitudes south of San Francisco Bay.

Pillbugs in the genus *Sphaeroma* are slightly larger than gribbles (up to $\frac{1}{2}$ inch in length) and resemble terrestrial pillbugs. Pillbugs, also known as marine sowbugs, are more widely distributed than gribbles, but not as numerous. Pillbugs are found in the coastal regions of Florida and Hawaii, and they have been found in freshwater as well as salt water.

Gribbles and pillbugs are difficult to control through the use of wood preservatives because they do not consume the wood fiber as they burrow into it. Wooden structures are actually only convenient shelters for them as they gather nourishment from the surrounding waters. One treatment method that has enjoyed success with these animals is the primary treatment of wood with copper-based wood preservative and then treating the timber with creosote. Another treatment that has been used is to encase piling in plastic or composite jackets that prevent both shipworms and the various crustaceans from establishing themselves.

Wood damage by nonliving agents

Wood-metal corrosion

The marine environment fosters conditions favorable to degradation of wood and metal when they are placed in contact with each other. There are many factors that contribute to this damage.

Use of dissimilar metal fasteners can set up galvanic current cells on the surface of a wooden structure. Galvanic cells can be established even when the dissimilar metals are several feet apart. The anode side of the current cell produces sodium hydroxide, a base that attacks the cell walls of wood fibers. The cathode side of the current cell produces hydrochloric acid, which attacks metal surfaces directly and promotes accelerated corrosion. Metal fasteners used to join wooden structures should be similar in composition and resistant to corrosion. If dissimilar metals are required for a fastening system, plastic insulators should be used.

Wood fiber contains a number of chemical agents that can corrode metal. Plants have extractive compounds like tannin that will stain and attack ferrous metals. Wood species vary in acidity, which can impact metal directly and also promote current flow in a galvanic circuit. Wood preservatives are often based on copper salts, which will corrode metal directly and also promote the flow of galvanic current. Wood also varies in moisture content which is needed to establish corrosion current cells.

Improper design can cause wood to hold excess moisture on surfaces and provide a path for the flow of electrical currents. Design of timber structures should prevent the presence of trapped water and exclude moisture. Bolt-holes should be slightly oversized and treated with extra wood preservative. Countersunk bolt-holes should be plugged and given an extra protective coating.

Harbor electrical design and maintenance also impact the wood-metal corrosion problem. Stray electrical current in a harbor and lack of adequate sacrificial anodes (zincs) installed on moored vessels can impose large currents on wooden structures. Management of wood-metal corrosion can be accomplished through good design and management of harbor facilities. The section in this book covering maintenance of harbor electrical systems lists a number of aggressive actions that can be taken to prevent and control stray utility current, to reduce electrical problems.

Salt degradation

Alternating cycles of wood wetted with salt water can cause the formation of salt crystals on the surface of exposed wood. This accu-

mulation of salt causes defiberization of wood cells near the surface of the impacted structure. As salt crystals enlarge, they eventually rupture the tracheids or cell walls of the wood fibers. Normally damage only occurs near the surface, and in even the most severe cases will only penetrate the wood surface 1 inch.

Chafing of timbers

Timber pilings can be damaged by the tidal movement of attached floating docks and debris. Chafing occurs at the piling hoop and can be aggravated by pilings that are not perfectly plumb. The presence and buildup of ice can also cause severe damage. Pilings can be protected from chafing by the use of metal collars on piling hoops. Rollers or strips of ultra-high molecular weight polyethylene (UHMW) material will also reduce wear.

Decay prevention

Keep moisture out

Decay can be prevented or reduced through proper handling of wood products during manufacturing, using proper storage procedures, and taking precautions to protect wood as part of design and construction. Protection of wood from continuous contact with water is the best way to prevent decay. Wood decay is not a factor until wood reaches its saturation point at about 30% moisture content. Dry wood may suffer surface mold, but it will not decay. Decay fungi need free water present in the wood to thrive. Temperatures that are comfortable for normal plant and animal life are also most advantageous for the growth of bacteria and fungi. Keeping the wood moisture content below 20% will prevent decay. Fungal growth can proceed rapidly between the temperatures of 10 and 35°C (50 and 95°F).

Some methods that can be used to protect wood include taking care to avoid damage to treated wood during installation in construction or heavy maintenance activities. Piercing the protective shell formed by the wood preservative compromises its protection and leaves weakened areas open to attack. Apply additional wood preservative to cut surfaces and bolt-holes created during construction. Avoid any boring or cutting of pilings below the waterline. Apply additional wood preservative to critical areas that trap water, such as blind joints and countersunk bolt-holes. Use commercially available wood preservative freely on these areas.

Use construction techniques and management procedures that prevent trapping of water. Examples include avoiding double



A. SORJUM

Wooden fender pile showing failure due to rot. While it is commonly thought that an angled cut helps shed water, this practice works against you by increasing the surface area.

decking of planking, not covering decked surfaces with plywood, and not covering wooden floating docks with indoor-outdoor carpeting. Attaching untreated wood to treated materials can provide a path for marine borers. The untreated wood is an attractive foothold for immature marine borers, which are sensitive to wood preservatives. Marine borers are more tolerant to the chemical preservatives as adults, and they can enter a treated piling after maturity. The cutoff ends of treated wooden piling require special attention to prevent rot from occurring.

One common practice is to cut pilings off at an angle to better shed water. All this practice actually does is increase the surface area exposed to conditions that promote rot. The treatment recommended to preserve piling tops is to utilize a commercially available wood preservative and then cover the piling with a fiberglass cone or roofing felt cap. Research shows that just the act of capping a wooden piling substantially reduces the chance of decay organisms infesting the wood.

Barriers made of ethylene propylene diene monomer (EPDM) plastics are available to wrap around wooden pilings. Wraps can be field-installed on existing structures, or piles can be shrink wrapped with plastic prior to driving. A plastic barrier physically prevents marine borers from entering the piling. Once in place, a barrier wrap will prevent the free flow of freshwater and oxygen needed by borers to survive. Plastic wraps also prevent damage from salt water in the splash zone and reduce friction when used with piling hoops.

Wood preservatives

Chemical preservatives have been used to treat wood for thousands of years. The Environmental Protection Agency (EPA) regulates wood preservatives. Only certified plants can apply current wood preservatives, with the exception of copper naphthenate. The raw chemicals are not sold to the public. Creosote, chromated copper arsenate, and ammoniacal copper zinc arsenate are the most common preservatives used in marine construction.

Industry standards are published by the American Wood Preservers Association (AWPA). The AWPA has numerous resources available at www.apwa.com. Topics include control of marine borers, the handling of treated lumber, and environmental impacts from wood treatment.

There are two broad categories of wood preservatives, based on the solvent used to dissolve the preservative chemical—water and oil. Following are brief descriptions of the commonly used marine wood preservatives.

Creosote

Creosote is one of the oldest wood preservatives in use. Creosote is made by distilling coal tar and is often thinned with mineral spirits or fuel oil. This preservative is very poisonous to wood-destroying organisms, does not leach into the environment, and does not dissolve in water. Creosote is ideal for use in pilings and marine timbers that don't come in contact with the public. It is oily and has a strong odor that is objectionable to some people. Contact with creosote-treated wood leaves you covered with a tar-like substance that is difficult to remove.

Chromated copper arsenate

Chromated copper arsenate (CCA) is a very popular preservative with an active ingredient based on copper salts suspended in water. It also contains chromium, which helps fix the preservative into the wood, as well as arsenic, which is toxic to wood-boring organisms and fungi. CCA, like creosote, has good preservative properties, low leaching, and several other advantages. It is paintable and odorless. There have been concerns expressed over the years about the safety of CCA-treated wood. Industry and government researchers hold that the treated wood is safe with proper use. Alternative materials have been developed and nonindustrial users of CCA-treated lumber started transitioning away from its use by the end of 2003. CCA-treated timber may still be used for marine construction projects in salt water.

Ammoniacal copper zinc arsenate

Ammoniacal copper zinc arsenate (ACZA) is an improved version of the old commonly used ammoniacal copper arsenate (ACA). ACZA was developed to treat Douglas fir, which is difficult for CCA to penetrate. ACZA has preservative properties similar to CCA and is one of the replacements available for CCA in nonindustrial use.

Pentachlorophenol

Pentachlorophenol (penta) is an excellent wood preservative, but is not recommended for marine applications because it leaches easily into the water.

Safety

CCA, ACA, and ACZA contain inorganic arsenic, which may pose a hazard to anyone exposed to it. The arsenic in these treated wood products is tightly bound at the cellular level. Hazards exist

only when the arsenic is leached out into the ground over a long period of time or released by the mechanical handling of the wood. The Environmental Protection Agency has issued some basic safety precautions for the handling, use, and disposal of treated wood products.

- Treated wood may be disposed of as normal trash.
- Treated wood shouldn't be burned in open fires, stoves, or fireplaces. The smoke and resulting ashes will contain arsenic.
- Dust from the cutting or sanding of treated wood can be a hazard. Wear goggles and a dust mask when there is the likelihood of prolonged exposure.
- Cut and sand treated wood outdoors whenever possible.
- Wash clothes that come into contact with treated wood sawdust and wash the clothes separately.
- Avoid using treated wood products where they might come into contact with drinking water, food, or animal feed.

Inspection for decay

Inspections for decay should be routine and a record kept of the effort. Tracking potential decay problems is a critical component of an effective harbor maintenance program. Decay can occur on the surface or interior of wood. Both external and internal inspections should focus on potential problem areas where locations are prone to be especially wet. Some of these situations include

- Open checks or cracks in large timbers, especially where the check is on the upper surface of a timber and can hold water.
- Exposed end-grain absorbs much more water (a factor of 50-100) compared to a timber's long grain. Designs that place the end-grain in vertical exposed position will make it prone to decay.
- Bolt and fastener holes should be predrilled prior to the pressure preservative treatment. Field-drilled holes need to be treated liberally with wood preservative.
- Overlay of decking with asphalt, or double-planking the deck surface, can trap significant amounts of freshwater on the wooden deck surface and promote decay.
- Lap-joints on bullrails (curbs) heighten the chance of decay by exposing a large surface area where the lap faces meet and trap water. Lap joints constructed in the field are difficult to adequately treat with wood preservative.



K. BYERS

This half lap joint on the bullrail, particularly prone to holding moisture, shows serious decay.

Any wood fastener is a potential point of infection and decay. Holes should be drilled for placement of driftpins and spikes to prevent excessive splitting and further exposure of wood grain. Avoid the use of oversized fasteners. Consider using screws to fasten wooden decking to floating docks.

Uncapped fender piling where the end of the piling has been cut off in the field are very prone to decay. A properly treated piling will resist attack from marine borers, but ultimately fail from rot progressing down from the top of the piling.

Visual inspections for decay can identify most external areas of concern. Consider the problem situations listed previously and areas where wood is constantly wet, especially from freshwater. A good flashlight or headlamp will help considerably in your efforts. Look for areas with abnormal staining or discoloration. Advanced decay will show depressed areas, shrinkage, checking, and often a dark brown coloration. Familiarize yourself with the appearance and smell of sound wood. Sound wood will have a resinous, crisp odor, while rot or decay will smell musty and dank. Watermarks, rust stains, moss, lichens, grass growth, and presence of fungal fruiting bodies and slime molds are all signs of excessive moisture.



The growth of grass between concrete and wood indicate excessive moisture.

Decay detection tools

Useful techniques for external evaluation of decay are probing, measuring, and photographing areas of concern. A tape measure is useful for defining the limits of a decay zone. A stiff metal ruler or feeler gauge is helpful for measuring the depth of cracks or checks. A sharp screwdriver or ice pick can be used to probe wood beneath a stained area for soundness. A digital camera is very valuable for documenting areas of concern in the inspection report.

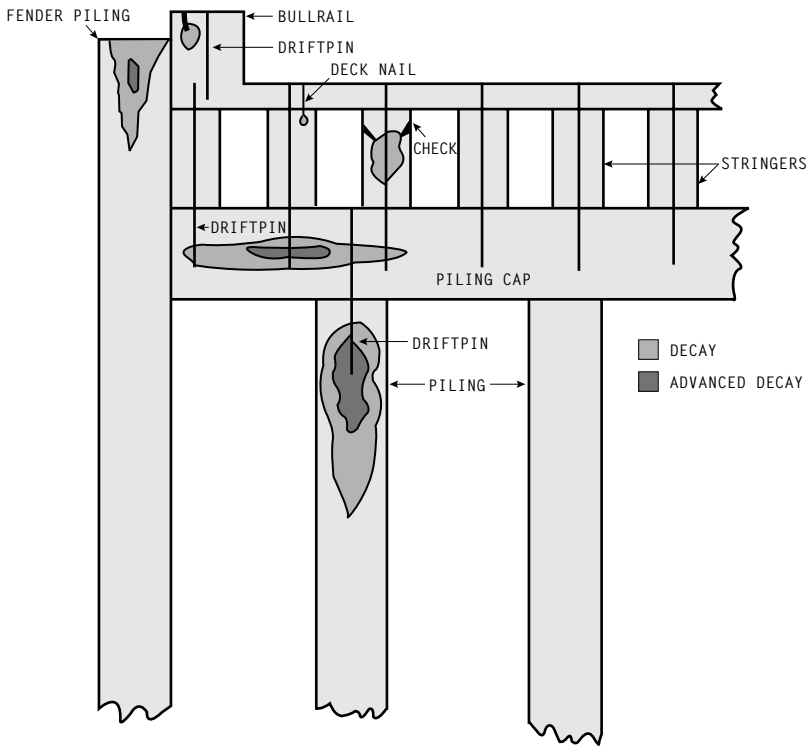

Dock cross section showing possible locations of decay.

Suspicious areas should receive further attention through sounding with a hammer, and core drilling suspect sites. Tools required for internal inspection of decay include hammers, bores, and moisture meters. A hammer is useful for sounding the surface of wood to detect areas of decay. Solid wood rebounds to the blow of a hammer, while an area of rot will have a muffled sound. Sounding with a hammer can detect larger areas of decay near the wood's surface with a little practice.

Areas identified by sounding should be cored. An incremental or coring bore is the most accurate, direct method available to detect decay. The coring provides a sample that can be physically inspected for decay and can also be cultured in a lab to determine the presence of fungi. Once an area of decay is found, work out from the site of the initial discovery and determine the limits of the decay.

Solid-state moisture meters have become very affordable and available for use in harbors. Probes can be driven into the surface

to gauge the moisture content of the wood. Saturation of wood fiber occurs roughly at 25% moisture content and indicates conditions prime for fungal infection and rot.

Maintenance and repair of wood structures

Proper maintenance of wooden structures includes routine inspection and timely repair of failed sections of the structure. The decks of wooden docks and floating docks should be pressure-washed, repaired, refastened, and treated with wood preservative annually. Wood structures will provide remarkable life spans with adequate care.

Moisture control will extend the life of wood structures through the reduction in rot and decay. Adequate drainage of docks, preventing accumulation of water, and avoidance of double-plank decking or asphalt overlays will extend dock surface life. Application of wood preservatives and caps will markedly improve the life of wooden piling. Plugging or treating countersunk bolt-holes and openings for other fasteners will help prevent fungal infection.

Repairs to wooden structures should be conducted with concern for the structural strength of the section being repaired. The following techniques will help with common repair tasks.

Bullrails

Bullrails (curbs) should be replaced in relatively long sections (longer than 10 feet). Bullrails are often important structural elements in both wooden and concrete dock systems. These timbers also take a great deal of stress from mooring lines and forgetful skippers. The most practical field splice for a bullrail is the lap joint. This joint is prone to retaining water, and fresh cuts to the wood need liberal treatment with wood preservative. Oversize holes for bolts and driftpins should be used for bullrail repairs.

Decking planks

Decking planks should be fastened with bolts or screws, depending on thickness. Nails will back out as wood swells and shrinks with the season. Apply liberal amounts of wood preservative to countersunk bolt-holes. Install planks with heartwood side down and stagger to ends so they don't form a single line across the dock. Replace planks with the same dimension lumber. Many floating docks are surfaced with 3 inch thick lumber, which isn't normally available at the local lumberyard. The temptation is to use 2 inch nominal thickness lumber, which is actually only 1 ½ inches thick.

Stringers

Stringers are the main structural members of docks, and floating docks and are most often damaged by collision or a hung piling hoop. A stringer can be difficult to access and repair. Decking needs to be removed to adequately expose the timber. One method of repair to use on a floating dock is a “sister” which is timber laid in on each side of the failed section. The sister extends at least four feet on each side of the repair site and is through-bolted to provide rigidity. Sisters are often useful in marine repairs where you don’t wish to remove a major portion of a structure. If a stringer on a loading or approach dock has failed due to decay, take time to assess the condition of underlying pile caps and piling. There is an excellent chance more decay is present, and you have done most of the work needed toward a repair once the stringer is exposed.

Cleats

Cleats, iron fixtures for tying mooring lines, are often attached to wooden docks. Avoid the temptation to use lag bolts! They will not hold. Use a through-bolt and consider using a backing plate if the timber is not adequately sound.

Chocks

Chocks and cross braces should be replaced in their entirety. These members are often broken or missing in many wooden docks and are important structural elements. Timely repair is preferred to a shortened dock life span or potential failure.

Steel

The use of galvanized steel has increased in design and construction of harbor and port facilities. Steel has had a traditional role in fasteners and support members, but it is becoming much more commonly used in piling and dock structures. Part of this can be attributed to local environmental concerns with wood preservatives and the long life of properly maintained steel structures.

The most common degradation of steel structures is corrosion due to exposure to seawater. Approximately 85% of all the surface water on the earth is sea or saline water. Typical seawater is composed of 3.5% salts. This level of salinity is normally expressed in parts per thousand. The Atlantic Ocean averages 37.5 parts per thousand and the Pacific Ocean runs 35 parts per thousand. Seawater is very corrosive and, more importantly, an effective electrolyte.

Dennis Nottingham's Method of Inspection for Open Cell Steel Bulkheads

A simplified method of corrosion inspection has been developed for Alaska's marine waters in areas of moderate to high tide ranges. Alaska's cool temperatures tend to minimize atmospheric corrosion, which is usually readily visible. But submerged steel will corrode in a manner similar to many parts of the world; this is Alaska's main corrosion problem.

Many areas of Alaska have high tide ranges with mean lower low water (MLLW) being the EL 0.0 datum. Some tide levels fall below MLLW, negative tide, thus exposing the most critical areas of corrosion for visual inspection. Superficial appearance of actively corroding steel will feature a bright orange layer over a black septic-like layer, over bright steel. The steel will usually show pits and uneven characteristics. Conversely, galvanized steel will show varying loss of coating, but with a smooth steel surface until all anode effects or the galvanization are gone. Cathodic protection will tend to coat steel with a gray-appearing layer gradually turning to brown and red as the effect diminishes.

In Alaska (excluding areas with silty, high-velocity current), approximate loss of bare steel in continuously submerged seawater is about 7 mils per year (0.178 mm), while loss in areas above low tideline will be much less, probably 1 to 3 mils per year (0.025 to 0.076 mm). However, loss from dissimilar metals (i.e., welds, bolts, etc.) can exceed many times these normal losses. Weld metal should be specified to have chemistry similar to base metal to help avoid corrosion acceleration.

Open cell structures are usually not highly stressed. Therefore, excessive cathodic protection with higher costs is not justified. A reasonable approach is to first assure that wye welds have protection, then space 200 pound maximum weight aluminum anodes at 15 foot maximum on centers below low tideline. In other words, no exposed steel area should be more than about eight feet from an anode. In ice environs place anodes below expected ice impact. Anode weld tabs connecting welds should be substantial to resist possible forces expected.

A typical aluminum anode should meet the following standards.

Element	Percent composition	
Zn	2.8 to 6.5	
Fe	0.120 max	
Cu	0.006 max	
Si	0.080 to 0.210	
In	0.010 to 0.025	
Hg	0.001 max	
Other	0.02 max	
Al	Balance	
Electrical potential (CuSO ₄)		1.15 v
Amp hours per pound		1,150 min
Efficiency		85% min

In clear water, anodes can best be welded under water. If placement from topside is required, anodes should be first welded to a channel, which can be partially submerged and then welded above waterline to the open cell. To avoid shaded zones under the channel, spaced round holes should be cut in the channel web to allow coverage and the channel should be galvanized.

Galvanized sheet piles will provide excellent atmospheric corrosion resistance and should serve as cathodic protection for 15 years more or less. A complete diving and topside inspection on five-year maximum intervals is recommended for steel structures, since anodes will come loose and leave zones unprotected and other repair needs may surface. At the time of inspection, corrosion rates exceeding those expected can be addressed, and new anode needs identified.

In 2001, cost of supplying and installing one 200-pound anode was estimated at about \$400-\$500, subject to mobilization, location variables, and number of anodes. Bare steel will use about 0.1 pounds per square foot of aluminum anode per year, but after initial consumption the rate will probably be about half that. A 200-pound anode should last about 15 years for a cost of 15¢ per square foot per year for steel area exposed to seawater from EL +2 downward.

There are two broad categories of corrosion—uniform, and general and localized. Bare steel in salt water can be expected to lose 5 to 10 mil per year in uniform corrosion. Localized corrosion is characterized by pitting and can reduce steel thickness at a much higher rate. Corrosion will be lower in a calm area like a mooring basin, and higher in areas with active wave motion. Atmospheric corrosion is a very strong possibility above active water in the marine environment.

Visual corrosion of a metal marine structure is caused by galvanic corrosion. Galvanic corrosion is a natural electrochemical process caused by the circulation of current between dissimilar metals in seawater. Corrosion involves two separate chemical reactions to occur—oxidation and reduction. We know from working on the waterfront that vessels utilize sacrificial zincs to protect bronze propellers, and harbors use aluminum anodes welded to steel pilings to protect them from corrosion.

Different metals have different levels of potential for chemical activity. Metals can be ranked by this level of activity in a galvanic series chart. Metals that are more active are also called anodic and metals that are less active are called cathodic or noble. Salts in seawater make it a good electrolyte.

Two dissimilar metals immersed in seawater will start generating an electrical current. Electrons will flow from the metal being oxidized (anode) to the metal being reduced (cathode). This is known as a corrosion or stress cell. The greater the potential difference in voltage between the two metals in seawater, the greater the damage from corrosion will be. Factors that influence the severity of corrosion are metallic composition, condition of the metal's surface, and the salinity of the seawater.

Galvanic Series Chart

Anodic or Active End

Alloy	Voltage Range
Magnesium	-1.60 to -1.63
Zinc	-0.98 to -1.03
Aluminum Alloys	-0.70 to -0.90
Cadmium	-0.70 to -0.76
Cast Irons	-0.60 to -0.72
Aluminum Bronze	-0.30 to -0.40
Red Brass	-0.30 to -0.40
Copper	-0.28 to -0.36
Lead-Tin Solder	-0.26 to -0.35
Admiralty Brass	-0.25 to -0.34
Manganese Bronze	-0.25 to -0.33
Silicon Bronze	-0.25 to -0.33
400 Series Stainless Steel	-0.20 to -0.35
90-10 Copper-Nickel	-0.13 to -0.22
Lead	-0.19 to -0.25
70-30 Copper-Nickel	-0.13 to -0.22
17-4 PH Stainless Steel	-0.10 to -0.20
Silver	-0.09 to -0.14
Monel	-0.04 to -0.14
300 Series Stainless Steel	-0.00 to -0.15
Titanium	+0.06 to -0.05
Inconel 625	+0.10 to -0.04
Hastelloy C-276	+0.10 to -0.04
Platinum	+0.25 to +0.18
Graphite	+0.30 to +0.20

Cathodic or Noble End

Corrosion cells can be created in a local area through a number of ways. The mud line of a piling can set up a change in oxygen levels above and below the soil. This is referred to as an oxygen concentration cell and promotes increased corrosion. The areas around welds can promote localized corrosion due to the effects of heat, dissimilar metals, and the impact to protective coatings.

Tactics to combat corrosion include anticipation of compatibility in the design process. The largest bulk of a marine structure should be the anodic metal, and it should cover as great an area as possible. Paint or a coating should protect noble or cathodic materials in the structure. Anodic materials are generally not coated. Another strategy is the use of galvanized steel in marine construction. In galvanized steel, zinc metal is deposited on the surface of a steel structure and provides sacrificial metal for the corrosion process. A rule of thumb is: a heavy, hot dipped coating of zinc will protect the underlying steel about one year for each mil applied. Electroplated zinc



K. BYERS

Galvanized sheet pile docks, like this one in Valdez Harbor, Alaska, have remarkable longevity in cold Alaska waters.

and cadmium coating are ineffective in protecting metal structures from seawater. Galvanized sheet pile docks have had remarkable success in our cold Alaska waters. Twenty-year-old docks show little sign of corrosion damage. Dennis Nottingham, P.E., has detailed a useful inspection procedure for open cell sheet pile docks.

Piling and other material installed below the mud line will not experience significant corrosion unless the soils are naturally corrosive themselves.

Concrete

Floating concrete seems an oxymoron, but concrete is a popular choice in harbors for encasing flotation and building solid floating docks. Cost used to be more of concern for concrete floating docks, but the cost of a quality wooden timber dock is not much different from a well-built concrete dock today. Concrete has a number of advantages: it is solid underfoot, stable, and can have a long service life with proper maintenance. Shortcomings of concrete include its inability to take a shock load and difficulty of repair on site. Concrete is very strong in compression, but not in tension. This is the reason reinforcing material is incorporated in the concrete as it is poured. When concrete is stressed near its failure point, it will not rebound like wood.

A good concrete floating dock system depends on excellent quality control. Your float manufacturer, shipper, installation contractor, and consulting engineer need to be working hand-in-hand through the entire construction process. Some companies combine these functions under one roof. A few harbors in Alaska have moved toward separate materials and installation contracts for the construction of new mooring facilities.

Concrete is porous and will absorb moisture over time. Freezing weather will induce cracking, spalling, and other deteriorating effects, including corrosion of the reinforcing steel. Spalling is the flaking of a concrete surface caused by expansion of freezing water adsorbed by the material. Durability is an essential property that needs to be considered in the construction of a quality concrete float. Durability is dependent on several factors: compressive strength, aggregate, permeability, air entrainment, water content, and quality control during construction. All of these factors combine to determine longevity and durability.

The water-to-cement ratio is a basic and most important consideration in concrete mix design. It has the single greatest impact on design strength and permeability of the concrete. In general, the



New concrete floating dock in Petersburg, Alaska. The dock rides a short distance up and down the poles, with the tide.

lower water-to-cement ratio used to batch concrete, the higher the compressive strength and impermeability of the concrete. The use of chemicals called super plasticizers has made lower ratios achievable while still allowing for a high degree of workability.

The new generation of concrete float technology has many advantages over earlier designs with respect to mix design, consistent specifications, quality control, and construction. Transpac Marinas of Anacortes, Washington, produces a high technology concrete float that can withstand severe weather and use. These monolithic-style floats use a minimum concrete thickness of 3.5 inch with 5/8 inch epoxy-coated reinforcement steel. The concrete mixture is engineered and strictly monitored for water content, air entrainment, and aggregate quality, and uses super plasticizers to enhance workability while lowering water content. Compressive strengths exceed 7,000 psi, which is more than double that of the first generation concrete mixes used in float construction. Super low water content also decreases permeability and thus the destructive nature of water absorbed by the concrete. The use of modern concrete sealants further reduces this effect. Transpac Marinas uses Steilacoom basalt, considered the “gold standard” in concrete aggregate for its strength and uniformity in size.

Maintenance and repair of concrete surfaces

Weathering of concrete is a concern in northern latitudes.

Water is able to penetrate the surface of the concrete and freezes. This expansion of water causes small areas to break loose from the surface, and is called spalling. Exposed reinforcing steel can also cause spalling. Rust occupies much more area than the base metal, and it can pop off the overlying concrete surface. Weathering and spalling of concrete can be prevented in many cases by insuring good quality control in concrete mix design, forming, and casting of float modules.



Degradation of concrete float, showing exposed reinforcing steel, grass growth, and standing water.

Routine maintenance can also help prevent water from seeping into the surface. The best method to use is to pressure-wash the surface of the concrete, allow it to dry completely, and treat its surface with a good quality concrete sealer. Moss and grass growing on the surface of the float or along the wooden whalers encourages more moisture to enter the concrete. Use a silane or siloxane-based penetrating sealer that is recommended by your local supplier. Plan to clean and reapply the sealer to concrete floats every few years to insure the floats are receiving regular attention. Cleaning and sealing the floats is a great opportunity to make other minor repairs to whalers and attachments.

The International Concrete Repair Institute (ICRI) has helped standardize the repair of concrete surfaces. The key is to properly prepare the surface and to avoid feathered edges around the patch. A number of special polymer modified patching compounds are now available to facilitate these repairs. ICRI has a Web page at www.icri.org.

Foam flotation

Foam flotation is a critical component in the construction of a successful floating dock. Many methods have been used to provide support for floating docks, including 55 gallon drums and log rafts.

There are three primary materials for foam flotation available today: extruded polystyrene, expanded polystyrene, and a copolymer of polyethylene and polystyrene. Expanded polystyrene (EPS) is by far the most commonly used flotation material found in floating docks.

Expanded polystyrene needs to be encapsulated or enclosed to ensure adequate utility and life span. Unprotected EPS has a limited life span and is considered an ecological hazard that does not biodegrade in the natural environment. Concrete, fiberglass reinforced plastic, polyurethane epoxy, solid polyethylene, and galvanized steel have all been successfully used to encapsulate EPS. Proper protection of EPS foam inhibits erosion by wave action, limits water absorption, and prevents attack by diesel or other hydrocarbons in the water. Well protected EPS foam billets can have a useful life span of more than forty years.

Good design practice requires stringent standards for foam flotation used in floating docks. Frederic Hunt, P.E., has worked with floating dock systems for many years and developed an industry standard absorption test for foam flotation. This test is called the "Seven Day Hunt Absorption Test." You will notice float system manufacturers stating they meet this standard in their advertising. The test procedure is included in this discussion to better familiarize you with the test. Most harbor managers will never conduct a Hunt test, but it is good to understand the importance of the standard and know it is available.

Several standards should be considered when purchasing flotation for a floating dock system. The following specifications will provide a good starting point for your own set of guidelines:

- Flotation will be extruded polystyrene, expanded polystyrene, or a copolymer of polyethylene and polystyrene.

Seven day Hunt absorption test for foam materials used as dock flotation

The purpose of the test is to get an early indication of the relative absorbcency of foam.

Test procedure

Precisely prepare $\frac{1}{16}$ cubic foot samples, at $5.0 \times 5.0 \times 4.32$ inch dimensions. Cutting is to be by hot wire, in a jig, in order to give consistent dimensioning. From a float five feet or less in length, it is recommended to take three samples—one from each of two diagonally opposite corners and one from the center. For floats over five feet in length, four samples are recommended at diagonally opposite corners and at the third points between corners.

Weigh the $\frac{1}{16}$ cubic foot sample on an accurate scale that reads in one-tenth ounces. Air dry the sample and weigh daily until the weight has remained the same for three consecutive days.

Put the sample foam block into a 5 quart or larger container, with the 4.32 inch dimension vertical. Fill the container to the top with water. A board will be placed on top of the container and a weight on top of the board. Put a $\frac{1}{2}$ inch thick spacer between the foam and the board so that the foam will be completely submerged with about $\frac{1}{2}$ inch head of water over the top. Water will have to be added every few days due to evaporation.

After 1 hour, and then at the same time each day for 7 days, remove the foam and weigh it. Lift the foam out of the water with one corner high and drain it for 5 seconds. Then place the foam on the scale, which will hold water running from the foam, and weigh it.

Subtract the dry weight, at the time of immersion, from the 7 day wet weight, to determine absorption for 1 cubic foot in ounces. Then divide by 16 to get absorption in pounds per cubic foot.

If the increase in weight is less than 3.0 pounds per cubic foot at 7 days then you have met the requirements for water absorption commonly called for in specifications of numerous governmental and private organizations.

- Flotation will have a minimum density of 0.9 pounds per cubic foot.
- Flotation will absorb less than 3.0 pounds per cubic foot at seven days when tested by the Hunt absorption test.
- Encasement will be solid polyethylene with a minimum thickness of 0.125 inches or a polyurethane epoxy coating with a minimum thickness of 50 mils. Damage, nicks, field cuts, and abrasions caused to polyurethane epoxy-treated foam billets during installation will be repaired with application of additional coating.
- Flotation will be warranted for a minimum of eight years against becoming waterlogged, losing beads, cracking, peeling, or fragmenting.
- Flotation will resist puncture and penetration, and not be subject to damage by animals.

Flotation needs to be protected during the construction and installation of floating docks. Floating debris brought in by river or tidal currents and ice can also damage flotation. Harbor float systems subject to grounding due to extreme water levels need to have ESP foam billets with extra strong encasements. Flotation provides support for the live and dead loads that must be carried by your floats. Recreational docks may need to carry only 20 pounds per square foot while a commercial facility might specify a minimum loading of 40 pounds per square foot. Carrying capacity of your float system is an important consideration that needs to be discussed with your design engineer.

8

Dockside cranes and straddle hoists

Dockside cranes

Dockside cranes are a common, important piece of equipment found at most harbors. Dockside cranes are used to transfer fish products and other marine-related cargo from vessels. Safe and successful use and maintenance of cranes depends on close surveillance of the equipment. Management of cranes should involve an overarching plan that includes inspections, access control, operator training, and legal user agreements for use of the equipment.



Dock-mounted crane, often referred to as a “hoist.” Cranes are used to move cargo to and from vessels.

Crane inspections

Inspections are important and while legal requirements concerning whether formal certification is required for a particular facility may vary, certification greatly improves safety and operational readiness of the equipment. Trained harbor employees should conduct crane inspections daily, monthly, and yearly. The inspector issues the certification documents. Following is a brief description of the types of inspections.

- **Frequently:** On the day of each use, a designated person should visually inspect for defects in functional operating components and report any defects found. **Monthly:** On a monthly basis, a designated person should thoroughly inspect all functional components and accessible structural features. Any defects should be reported. A record of monthly inspections should be maintained for six months.
- **Annually:** On an annual basis, an OSHA-accredited inspector should examine each crane.
- **Every four years:** Each crane should be load tested every four years.

Crane access control

Access control involves providing a means to limit use of a crane to qualified users. There are many systems available for harbors to consider. The simplest method available to control access is to lock the crane controls and require users to sign out the key from the harbor.

Valdez harbor adopted a wireless control system provided by ALX Technology, www.alxtechnology.com, which is simple to install, is very robust, and provides billing information to our marina management software system. Harbor users must be issued a proximity reader card from the office, which is tied to the users' accounts for billing purposes. A crane user holds the access card up to a reader mounted on the crane that activates it and identifies the user. An added benefit is a complete record of users and hours of operation. The record helps eliminate mystery abuses of the equipment.

Crane operator training

Operator training is necessary for safe operation of any piece of lifting equipment. Training improves safety, but is also a very important consideration in facility risk management. A good training system provides a record that proves your facility has made a good



The access card reader box, using ALX technology, on a crane in Valdez Harbor, Alaska. This system provides a complete record of users and hours of operation.

faith effort to offer a safe environment for customers. ARXCIS, Inc., www.arxcis.com, developed a training course for dock crane operators that has been adopted by the Alaska Association of Harbormasters and Port Administrators (AAHPA) statewide in Alaska. An operator who qualifies at one harbor in the state has their training recognized by other member facilities. ARXCIS's course is provided on CD and uses Microsoft PowerPoint software. A short quiz is given after each section and a final qualification test is presented at the end of the course. Successful candidates are then issued an operator's card and certificate of completion for the course.

Marine straddle hoists

Many harbors in Alaska operate marine straddle hoists, or boat lifts. Marine Travelift Inc. of Sturgeon Bay, Wisconsin, is the major provider of marine straddle hoists in Alaska. The term "Travelift®" is commonly used for "marine boat lift" in Alaska. A straddle hoist is a basic square steel frame, mounted on tires, equipped with wire rope winches that operate nylon slings to lift the vessel. Rated capacity can vary from 15 to 1,000 tons, and the lifts require a dedicated dock structurally able to support the equipment and vessel being lifted. Lift dock construction is similar to other styles of marine docks and they use the same available building materials.

Owners of marine straddle hoists are required to designate a person responsible for ensuring the equipment is safe to operate for each use. This is accomplished primarily with a daily checklist. If the lift is noted as needing repair, the problem has to be resolved prior to use. It is very important that a broken lift not be left for later use by another operator. A defective lift should be locked out or disabled until it can be properly repaired. Marine Travelift Inc., and many private crane certification companies, offer daily checklists for operator use. The applicable OSHA regulation for marine straddle hoists falls under Subpart N Section 1926.550—Cranes and Derricks.

Numerous safety concerns need to be addressed each time a marine straddle hoist is operated. Marine Travelift Inc., and the American Boatbuilders and Repairers Association (ABBRA), offer formal lift operator training for harbors. In addition to the major safety concerns listed below, each harbor will have unique local safety problems to consider.

- Marine straddle hoists utilize nylon web slings to pick up boats. The slings are rated for a particular load and use. Nylon slings

are subject to damage from cuts, dirt, abrasion, and misuse. Slings need to be inspected visually prior to each use. Many manufacturers include red tracer threads or yarns within the nylon web to help identify damage from abrasion or overloading. Utilize protective chine and keel pads to protect and extend the life of the slings. It is a good practice to replace slings every year.

- Newer marine straddle hoists can be equipped with wireless remote control. If your facility has a chance to purchase a new lift, make sure you specify this option for your machine. Operation of a lift with remote control is much safer and easier for your operator. The lift operator can walk completely around the lift and the boat being lifted while it is running, and see everything that could be in the way or struck by the equipment.
- Your marine straddle hoist, wire ropes, winches, nylon slings, and lift dock are engineered to lift a specific load. Use proper care and maintenance to ensure that your equipment can handle its maximum rated capacity. Avoid overloading the weakest component of the lift system. Most lifts have visual indicators to display the weight being lifted. Loads must be evenly distributed between slings and from front to back on the lift.
- Marine straddle hoists and power lines do not mix. It is very easy to come into contact with a power line, due to the height of the boat lift and vessel components like masts protruding above the lift itself. Under many lighting conditions, the power lines can be very difficult to see from a lift. Show your lift operator the limits of the boat lift operation by walking through the boatyard and physically inspecting the facility. This can greatly reduce the chance of a tragedy later.
- There are conflicting legal arguments focusing on harbors blocking up boats after they are lifted. One camp contends that if the vessel owner provides and places the boat stands and blocks, the facility is not responsible for any damage that might occur to the boat. The opposite argument is that if a harbor provides highly trained personnel to block up vessels in the yard, the chance of an accident is greatly reduced and the actions of staff can be more easily defended by the use of accepted industry standards for blocking boats. If your facility decides to offer blocking service for boats using your yard, be sure employees are trained to the standards promulgated by ABBRA.
- Many harbors maintain a photo album with pictures taken of each boat lifted. This provides the operator with a ready refer-

ence to where slings should be located on the vessel for a safe lift. The photo album also provides a suitable space for recording notes of unique characteristics of the boat, and can be a great resource for the harbor in the event of any litigation related to a boat lift.

Both Marine Travelift Inc. and ABBRA use the same person, Paul Doppke of Huff Ltd., to conduct their lift operator certification training. Through ABBRA, a harbor can host a training session and have part of their staff trained for free. The host harbor provides a lift and operator; for every fourteen students enrolled, the host harbor receives free training for two of its employees.

The Alaska Association of Harbormasters and Port Administrators took advantage of this program at its annual meeting in Seward, Alaska, in 2003, and trained thirteen marine straddle hoist operators. Cost for the class is around \$300 per student and certification is good for three years. Bringing the trainer to the harbors has proved to be a good way to get the certification required for operators in the field, especially with the distances involved with travel out of region. Contact information for marine straddle hoist training provided by Paul Doppke is included in Appendix C of this book.



K. BYERS

Owners of marine straddle hoists are required to designate a person responsible for ensuring the equipment is safe to operate for each use.

9

Potable water systems

Potable water systems in small boat harbors are often cobbled together from whatever materials are locally available. The final product can vary widely. Important considerations for the design of water systems include safety, performance, and maintenance. Equipment used in water systems must be able to protect the water quality and not be a source of contamination. Most vessel water systems cannot tolerate the high pressure found in many municipal



K. BYERS

The galvanized steel guard on this set of hose bibs helps prevent damage from vessel strikes.

supply systems. Unless you are fortunate enough to manage a harbor in the southern United States, plumbing will need to be protected from freezing.

Water systems will never fail in your harbor at a convenient time. The best suggestion for management of water system repairs is to standardize every part in every location of your facility. That means keeping mainlines the same size, keeping lateral lines the same size, and using the same hose bibs throughout the facility. Maintain a supply of spare parts for your system in a repair kit that is readily available. The alternative is trying to repair a water line break in the middle of the night when the hardware store isn't open.



The convenient hose hanger, for the potable water system in Valdez Harbor, Alaska, was designed by Tryck, Nyman, Hayes, Inc.

Every harbor is unique and its water system should be designed to best fit the local needs. A system that has been put to use in Valdez Harbor has high density polyethylene (HDPE) piping. HDPE pipe comes in standard 20 foot lengths and nearly any diameter you could imagine. The pipe is joined with a fusion welding machine that produces splices just as strong as the rest of the pipe. HDPE resists damage caused by freezing and impacts.

Valdez Harbor used 2 inch HDPE pipe for its mainlines running down the floating dock. The pipe is suspended in the water from the dock to prevent freezing. Every 50 feet a 1 inch tee fitting was welded into the mainline. The tee outlet is fitted with a ball-valve, a section of vinyl tubing, and a cam lock quick-disconnect fitting. Water is provided to the hose bibs with the vinyl tubing. This arrangement allows the hose bibs to be disconnected when not in use during freezing weather. The supply tube is shut down and thrown over the side of the dock to keep it from freezing. The end of the tubing has a piece of polypropylene line attached to it and the dock. The beauty of this system is that the mainline can remain charged during our severe winters, and the few year-round residents living in the harbor can enjoy reliable water service. This system is easy to maintain and repair. It has saved us more than \$5,000 a year in repair charges that we used to pay for our old iron pipe system, including hiring divers.

10

Harbor electrical systems

Harbor electrical systems should be engineered to conform with NFPA 303, which sets safety standards for marinas and boatyards, and the National Electric Code NFPA 70. These codes provide guidance on the wiring, conduit, receptacles, and service equipment that should be used in a marine environment.

Typical harbor electrical systems get power from a local utility to a transformer. The transformer, main service disconnect, and master meter are normally located together at the head of an approach dock. Most harbors provide a 120/240 volt, single phase electrical service; larger commercial facilities have 120/240 or 480 volt, three phase power available as well. Secondary service to the harbor comes from the main disconnect, and travels under the dock and gangway to a distribution panel. The distribution panel provides a way to divide the power into branch circuits. A common arrangement is to provide a separate circuit for each primary floating dock in the basin. The panel would have a main disconnect breaker and a circuit break for each float.

Power cables for newer style floats are normally run in a utility tray on wooden floats and a utility trench or duct on concrete floats. Older wooden floats may have cable suspended from whalers or stringers. Power cables then terminate at individual meter bases that are equipped with their own circuit breaker and power receptacle. Harbor power receptacles need to be UL approved and fitted with a self-closing, gasketed cover to keep out moisture. You'll find receptacles burned up in your harbor from time to time. The chief cause is moisture in the receptacle providing a path to ground (salt water) from the hot lead of the electrical system.



K. BYERS

Power cables terminate at a meter base, which contains the circuit breakers and power receptacles for each moored vessel. This double meter base has self-closing, gasketed covers.

Harbor electrolysis/corrosion

Any vessel moored in a harbor is subject to the corrosion of its metal surfaces that are exposed to the marine environment. Two different processes—galvanic corrosion and electrolysis—can cause damage to vessels. Galvanic corrosion is caused when two dissimilar metals come into contact with each other while immersed in an electrolyte like salt water. Electrolysis is caused by the existence of potential current between two different objects. These objects can be aboard a single vessel or involve multiple vessels. This section offers some ideas on how to reduce corrosion in your harbor, but does not cover the topic thoroughly.

Galvanic corrosion

Galvanic corrosion is similar to the operation of a battery. Two dissimilar metals in contact with an electrolyte create a natural electrical current. The lead/zinc-acid battery in your boat is an excellent example. Prevention of this problem is based on good planning and knowledge of what's being used on your vessel. These are some potential causes of galvanic corrosion:

- Using dissimilar metals on the vessel that come into contact with the salt water. This could include using steel bolts or copper-based bottom paint on an aluminum hull.
- Mixing different types of bottom paint on the same vessel.
- Mooring vessels with incompatible hull construction next to each other. An example would be a steel vessel placed immediately next to an aluminum vessel.

Electrolysis

Electrolysis is a form of corrosion that is the result of potential current between two different objects. It is normally caused by stray electrical current. Electrolysis is much more destructive than galvanic corrosion. To prevent electrolysis, the vessel must be wired properly and outside sources of stray current must be identified. These are a few possible sources of electrolysis:

- Using a common automotive battery charger. Most of these chargers have their primary and secondary transformer windings electrically connected which allows stray current to enter the vessel's grounding system. Use a marine rated charger, which will have an isolation transformer to prevent current passing across the charger's windings.
- A welder using DC current can induce a current into the water if any of the welding cables are frayed or bare. A better solution is to place the welder on the vessel being repaired.
- Having two bilge pumps with their connections reversed, i.e., the frame of one pump negatively grounded and the frame of the second pump connected to the positive side of the electrical system.
- The ground and neutral of the vessel's electrical system are not isolated or the shore power cord is improperly connected. Power should be taken only from the hot and neutral terminals. Drawing power from the hot and ground terminals will induce stray current into the harbor and pose a hazard to anyone in the water near the vessel.



Marine transformer (note non-approved cord).

Your harbor should have policies in place that regulate the use of shore power cords to help reduce stray current and fire hazards. Cords need to be designed for marine use, and kept out of the water while connected to a vessel. The typical household extension cord is not acceptable. The Valdez Harbor Fire Safety Plan details some of these electrical safety requirements as an example. They include the following.

- Electrical systems and equipment used within the harbor will comply with NFPA 70, National Electrical Code, and Chapter 3 of NFPA 303.
- Cords with current carrying capacity of less than 15 amps will not be used. Flexible cords will be used only in continuous lengths without splicing or taps.
- Cords, attachment plugs, and connector bodies will not be smaller than required for the rated current of the attached cord or connected equipment.

- Infrared heating lamps may be used only with porcelain-type sockets.
- Any heater capable of causing a fire if overturned must be equipped with a safety switch that will disconnect electric current to the heater, if it is overturned.

Much of this information is derived from *Harbor Electrical Guidelines* published by the Alaska Department of Transportation and Public Facilities.

Lighting systems

Lighting systems function to provide harbors with illumination to ensure safety, promote security, and extend operational hours. There are several methods available to extend lighting systems into harbors. Each has its advantages, and community requirements will drive the final design.

High-mast lights

Valdez Harbor has high-mast lights, mounted on 110 foot towers. Each tower has a cluster of 4 to 6 1,000 watt high-pressure sodium light fixtures mounted to it. Advantages of this system are the uniform illumination of the entire mooring basin and the elimination



Night lighting in Kodiak Harbor, Alaska.

of light fixtures from the floating dock. Alaska winters are dark and there is a definite safety advantage to being able to see activity in the fairways and away from the docks. A person in the water or vessel in distress is very visible with this lighting system. We have found from a maintenance standpoint that when we work on a tower it pays to replace all the bulbs at one time. This eliminates repeated trips to the tower and insures better performance throughout the rest of the year.

Float-mounted lights

Lighting can be installed directly on floating docks through the use of dedicated fixtures or lights integrated into power pedestals. Dock-mounted lights provide good illumination of walking surfaces and are energy efficient. Lighting is indirect and does not blind incoming boaters.



K. BYERS

High mast lights mounted on 110 foot towers, in Valdez Harbor, Alaska. This tower has six 1,000 watt high pressure sodium light fixtures.

Piling-mounted lights

Older harbors in Alaska still have light fixtures mounted directly to float pilings with electrical conductors strung from piling to piling. This lighting system can be inexpensive and readily installed by a local electrical utility company. Care must be exercised in a couple of areas.

Electrical conductors can come into close proximity to people walking on the docks at high tides. Pilings are flexible and there is a fine line in many harbors between keeping the cables tight enough to stay out of reach and loose enough to allow for movement of the piles. Maintenance seems to be high with these systems in Alaska harbors, but this may be in part due to the 30+ year age for many of these systems. Inspection items of interest include the condition of conductors, water in fixture lens, broken lens, height from the dock, and attachment to the piling.

11

Future developments in harbor operations

Harbor maintenance management software

I have often thought over the years that there is a substantial need for a management software program that addresses the needs of harbors. Maintenance priorities must be based on cost, benefit, public health and safety, available resources, and overall strategic planning. Effective harbor operation depends on having an overall inventory of harbor facilities, including the total replacement cost of all installed harbor infrastructure.

A truly useful effort would be an overarching maintenance program that includes these components and abilities:

- Has the ability to track time and material costs.
- Integrates operation and maintenance (O&M) manual recommendations with work in the field.
- Automatically generates work orders on a timely basis using O&M recommendations.
- Maintains an overall database of infrastructure values and historical maintenance costs for improvements. There should be a tie-in with Governmental Accounting Standards Board Statement 34 (GASB-34) requirements.
- Provides predictions of useful life and time of most economical replacement for structures.
- Utilizes a geographic information system (GIS) interface that integrates a library of as-built drawings and O&M manuals for the entire harbor system.

- Has a library of O&M manuals and as-built drawings for harbor infrastructure.
- Determines appropriate level of maintenance funding needed to adequately preserve harbor improvements.

Harbor employee training

The International Marina Institute (IMI) has done a remarkable job of developing professional accreditation of marina managers. The regional organizations, Pacific Coast Congress of Harbormasters and Port Managers (PCC) and Alaska Association of Harbormasters and Port Administrators (AAHPA), have been working to develop training appropriate for harbor officers and employees. An effort is currently under way to develop a vocational education program for harbor employees at the University of Alaska Southeast in Ketchikan.

The concept is to provide training in the basic skills needed by employees working in harbors, and develop courses that are graduated in effort and difficulty. PCC and AAHPA would provide accreditation for people who complete the training. This accredited training would then be recognized by member harbors along the West Coast of the United States. Establishing professional standards for required harbor employee education will benefit both harbors and harbor users.

Port and facility security

The “new normalcy” has impacted the harbors of Alaska. Harbor employees are the first people to see and observe unusual events occurring at their facilities and they need to make them known to the Coast Guard and law enforcement agencies. Harbors represent potential security risks as targets of possible attacks to their facilities, and could also provide vessels that might be used in terrorist attacks against other targets. Cooperation and relations with the local Coast Guard Captain of the Port will increasingly influence the future operation of your marine facility.



K. BYERS

Cooperation with the local Coast Guard Captain of the Port will help ensure the secure operation of your harbor.

References

- Alaska Department of Transportation and Public Facilities. 2004. *Coastal and Harbor Design Procedures*.
- American Wood Preservers Institute. *Construction Guidelines for Timber Piling Projects*. awpi.org.
- Beckham, J.B. 2000. *A Report on the State of the Harbor*. City of Seward, Alaska.
- Fisheries and Oceans Canada. 1998. *Harbour Authority Manual*. Small Craft Harbours, Canada.
- Halbach, T.R., and D.R. Baker. 1991. *Composting Fish Waste: An Alternative for Minnesota Resorts*. University of Minnesota Sea Grant Program. 18 pp.
- Highley, T., and T. Scheffer. 1989. *Controlling Decay in Waterfront Structures*. U.S. Department of Agriculture, Forest Products Laboratory.
- Hild, C. 1997. *Hazardous Materials on Board*. Alaska Sea Grant College Program, University of Alaska Fairbanks. 34 pp.
- Lowell, L.P. 1997. *Harbor Electrical Guidelines for Maintenance and Operations, Design and Construction*. Alaska Department of Transportation and Public Facilities, Juneau.
- Morris, Helsing & Graham. 1984. *Marine Wood Maintenance Manual: A Guide for Proper Use of Douglas Fir. I. Marine Exposures*. Oregon State University, College of Forestry and Sea Grant College Program.
- Neil Ross Consultants & Concepts Unlimited. 1995. *BMP Examples for Alaska*. Alaska Office of the Governor.

- Northern Economics, Inc. 2004. *Harbor Economic Impact Model User's Manual*. Alaska Department of Transportation and Public Facilities.
- Peratrovich, Nottingham & Drage, Inc. 1985. *A Guide to Maintenance of Small Craft Harbors*. Alaska Department of Transportation and Public Facilities.
- Peratrovich, Nottingham & Drage, Inc. 2003. *Permeable Wave Barrier Feasibility Study*. Valdez, Alaska.
- Port of Anacortes. *Management Practices for Handling Used Oil*. Anacortes, Washington.
- Sorum, A.J. 2002. *A Report on the State of the Harbor*. Valdez, Alaska.
- Sorum, A.J. 2003. *A Comprehensive Vision for Valdez Harbor Expansion and Marine Related Development: The Valdez Marine Center*. Valdez, Alaska.
- USDA. 1999. *Wood Handbook: Wood as an Engineering Material*. U.S. Department of Agriculture, Forest Products Laboratory.
- HDR Alaska, Inc. 2004. *Marine Facilities Management Handbook*. Aleutians East Borough.
- Wolf, Snow, & Glenn. 1993. *Marina Operations Manual*. International Marina Institute.

Appendix A

Americans with Disabilities Act compliance

Port and harbor designers must provide an accessible route that includes upland facilities, access to floats, and accessible slips. Current guidelines address newly constructed and significantly altered facilities. However, the ultimate goal of the Americans with Disabilities Act (ADA) is to provide full access to existing facilities as well.

The Americans with Disabilities Act of 1990 prohibits discrimination based on disability. The Federal Access Board recently issued Accessibility Guidelines for Recreational Facilities. Published in the Federal Register 36 CFR parts 1190 and 1191, these guidelines are effective as of October 3, 2002. Sections 15.2 and 15.3 provide guidance for Boating Facilities and Fishing Piers and Platforms, respectively. These accessibility guidelines will serve as the basis for the Department of Justice standards, and will be incorporated into Americans with Disability Act Accessibility Guidelines (ADAAG) by about 2007.

1. When Does It Matter?

It matters when you are constructing a new facility or significantly modifying an existing one. In existing facilities, modifications should be built to accommodate people with disabilities if possible. "What you touch, you fix!"

You must provide program access. A community with several harbors may or may not need to provide access at all of their facilities, especially if they vary greatly in function.

Make employment accommodations. Correct them as the need arises in existing facilities, but remember employment seekers

as well. That is, make sure your application process allows for people with disabilities to get applications, apply, and interview.

2. Accessible Routes

Gangways and other accessible routes must comply with ADAAG 4.3. At least one accessible route connects accessible buildings, facilities, elements, and spaces on the same site. Therefore, an accessible route must connect accessible boat slips with other accessible elements on the same site. Eight exceptions, listed below, modify the accessible route requirements for connections to floats. Note: Accessible routes to fixed piers must meet all requirements of ADAAG 4.3. There are no exceptions.

Accessible routes including those with gangways must comply with the rules in ADAAG (4.3), except:

- A. In existing gangway(s) replaced or altered; increase in gangway length is not required by 4.1.6(2).
- B. Maximum rise does not apply.
- C. If the total gangway length is at least 80 feet, maximum slope (1:12) does not apply. Note that if your tide range and elevations allow a gangway to meet the maximum 1:12 slope criteria with a gangway that is less than 80 feet long, that is allowable.
- D. In facilities with fewer than 25 slips, total length of gangway must be minimum 30 feet. Maximum slope doesn't apply.
- E. Gangway connection to transition plates, landings (4.8.4) don't apply.
- F. Handrails at connections to transition plates aren't required. Handrail extensions don't need to be parallel to float.

Cross slope of gangways, transition plates, and floats shall be a 1:50 maximum. Limited-use (limited-application) elevators or platform lifts can be used in lieu of gangways.

3. Number of Accessible Slips

The minimum number of accessible boat slips required varies from 1 to 12, depending on the size of the harbor. For example, a harbor with 300 slips requires five accessible slips, whereas a harbor with 301 slips needs six. Every 40 feet of linear moorage is considered one slip for this calculation.

4. Dispersion of Accessible Slips

Types of boat slips are usually based on parameters such as:

- Size (length)
- Configuration (single or double)
- Water depth
- Transient or assigned
- Covered or uncovered
- Utility access

Accessible boat slips must include the various types of slips provided at a facility. This provision doesn't require an increase in the minimum number of accessible boat slips.

Total boat slips in facility	Minimum number of required accessible boat slips
1 to 25	1
26 to 50	2
51 to 100	3
101 to 150	4
151 to 300	5
301 to 400	6
401 to 500	7
501 to 600	8
601 to 700	9
701 to 800	10
801 to 900	11
901 to 1,000	12
1,001 and over	12, plus 1 for each 100 or fraction thereof over 1,000

5. Use of Accessible Slips

Accessible boat slips are not “reserved” like vehicle parking spaces. Rather they are comparable to accessible hotel rooms. Accessible hotel rooms are held until all other rooms are filled. Then they are used on first-come, first serve basis.

6. Boat Launch Ramps

You must provide an accessible route to the launch ramp float. At least 5 percent (but not less than one boat launch ramp) shall be served by an accessible route with three exceptions:

- A. Floating access is subject to exceptions for accessible route (1,2, and 5 through 8 above, i.e., gangway-related exceptions).
- B. The minimum is a 30-foot gangway.
- C. Where an accessible route is within a boat launch ramp, it is not subject to the rise, slopes, and other provisions of ADAAG 4.8.

This means that the boat launch float can lie on grade as they do currently. But, there must be an accessible upland route and the floats, where boarding occurs, must conform to the accessible slip requirements.

7. Accessible Boat Slips (15.2.5)

The basic requirements (See Fig. 59) for an accessible slip are:

- Clear pier space of 60 inches wide minimum at least as long as the accessible slip
- Every 10 feet maximum of linear edge contains at least one 60 inch minimum opening

Clearances: Exception 1

The clear width can be 36 inches (915 mm) minimum for a length of 24 inches (610 mm) maximum, if multiple 36-inch (915 mm) wide segments are separated by 60 inches (1,525 mm) minimum clear in width and length. (See Fig. 60)

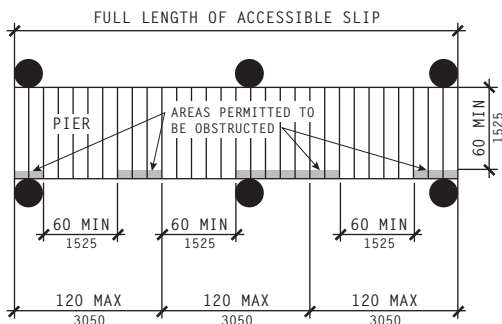

Fig. 59. Pier clearances

Clearances: Exception 2

Edge protection 4 inches (100 mm) high maximum and 2 inches (51 mm) deep maximum are allowed at the continuous clear openings. (See Fig. 61)

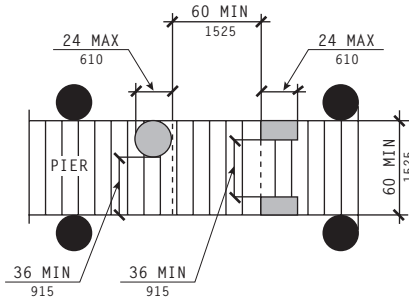

Fig. 60. Pier clear space reduction

Clearances: Exception 3

In alterations to existing facilities, clear pier space can be perpendicular to, and extend the width of, the boat slip. This is only where the facility has at least one boat slip complying with 15.2.5 (accessible slip requirements), and further compliance would result in reductions in the number of boat slips available or result in a reduction of the widths of existing slips.

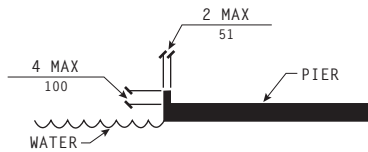

Fig. 61. Edge protection at pier

8. Cleats and Other Boat Securement Devices

Cleats and other tie downs don't need to comply with 4.27.3 reach ranges for operating mechanisms.

9. Other Harbor-Related

Newly designed or altered fishing piers and platforms are covered under A15.3. Like harbors, fishing piers need a fully accessible route. Railings, edge protection, and height are also specified.

10. Resources

U.S. Federal Access Board at www.access-board.gov.
(800) 872-2253 (voice) or (800) 993-2822 (TTY), weekdays 10-5:30 EST.

Alaska Department of Labor at www.labor.state.ak.us/ada.

Access Alaska, ADA Partners, Technical Assistance,
(907) 248-4777.

Alaska DOT&PF, Ports and Harbors Section, Coastal and Harbor
Design Procedures Manual

Appendix B

Harbor-related legislation, regulations, and programs

State of Alaska Laws and Regulations, and State Agencies

The primary state agencies involved in the development and implementation of regulations and programs to (a) manage and protect local resources, habitat, and water quality and to (b) develop facilities in coastal areas include the Department of Environmental Conservation (DEC), the Department of Natural Resources (DNR), the Office of Project Management and Permitting (OPMP), and the Alaska Department of Fish and Game.

The Alaska Department of Environmental Conservation's mission is to protect the public health and the environment, conserve and maintain air quality, control oil pollution, respond to oil and hazardous substance spills, and oversee management and disposal of solid waste and wastewater.

The Alaska Department of Natural Resources manages tidelands and land. The former habitat division of the Alaska Department of Fish and Game now resides within DNR as the Office of Habitat Management and Permitting.

The Office of Project Management and Permitting (OPMP) is the lead agency for coordinating the Alaska Coastal Management Program (ACMP). It coordinates state oversight of projects that require state or federal permits to ensure they are consistent with the ACMP and approved coastal district programs.

State plans that address nonpoint source pollution

The Alaska Coastal Clean Water Plan

The plan responds to the federal Coastal Zone Act Reauthorization Amendments (1990). It contains management measures for harbor and marina activities, and cites state programs that meet the measures. The management measures addressed include sewage facilities, solid waste, solid waste from tidal grids, fish waste, liquid material, petroleum control, boat cleaning, public education, and maintenance of sewage facilities.

Alaska's Nonpoint Source Pollution Strategy, September 2000

Section VII, Harbors and Marinas, summarizes sources of pollution from harbors, Alaska Department of Transportation (DOT&PF) resources (Alaska Coastal and Harbor Design Procedures Manual), and harbor management agreements. It also identifies action plan objectives and tasks.

Applicable Alaska Administrative Codes (AACs)

Title 6: Government Process

Chapter 80.130: Standards of the Alaska Coastal Management Program: Habitats

Title 17: Transportation and Public Facilities

Chapter 80: Water and Harbors

Title 18: Environmental Conservation

Chapter 60: Solid Waste

Chapter 62: Hazardous Waste Management

Chapter 64: Litter Receptacles

Chapter 75: Oil and Other Hazardous Substances Pollution Control

Applicable Alaska Statutes (AASs)

Title 16: Fish and Game

Title 30: Navigation, Harbors and Shipping, Miscellaneous Provisions, Discharging Ballast Water into Navigable Waters

Title 46: Water, Air, Energy, and Environmental Conservation

Federal Laws and Regulations and Federal Agencies

The primary federal agencies responsible for implementing and enforcing the regulations summarized below are the U.S. Environmental Protection Agency (EPA), the U.S. Army Corps of Engineers (ACOE), the U.S. Coast Guard (USCG), the National Oceanic and Atmospheric Administration (NOAA), NMFS, and the U.S. Fish and Wildlife Service (USFWS).

The EPA is responsible for implementing the Clean Water Act (nonpoint source pollution program), the Resource Conservation and Recovery Act (solid and hazardous waste), Marine Plastics Pollution Research and Control Act, and parts of the Coastal Zone Act Reauthorization Amendments 1990.

The ACOE reviews coastal development projects and issues permits for placing fill in wetlands and navigable waters, and for dredging activities. The ACOE has been the lead agency in many of the recent feasibility studies for the expansion or development of new harbor facilities and docks in the borough.

The USCG, likely one of the more visible federal agencies out on the water, enforces maritime laws, including those related to safety and environmental protection. They have the power to board and inspect commercial and recreational vessels to ensure they are in compliance with a host of regulations, including for appropriate solid and sanitary waste facilities and for displaying applicable signage. The USCG also regulates and monitors harbor and port facilities.

NOAA has a less visible regulatory and enforcement role than EPA, ACOE, or USCG, but along with EPA shares responsibility for implementing the Coastal Zone Act Reauthorization Amendments of 1990.

NMFS has regulatory authority over many of the marine mammals that inhabit the coastal waters encompassed by the Borough, and USFWS manages seabirds, migratory birds, and bald eagles, as well as walrus and sea otters.

Federal Regulations

International Convention for the Prevention of Pollution from Ships (MARPOL)

Commonly known as MARPOL 73/78, this is an international treaty that sets out operational waste discharge requirements for ships. In the United States, MARPOL is implemented through the

Act to Prevent Pollution from Ships (1980). The intent of MARPOL is to limit shipborne pollution by restricting operational pollution and reducing the possibility of accidental pollution. MARPOL consists of five separate annexes, each one aimed at a particular class of pollutants. Regulations for port reception facilities are included under 33 CFR Part 158 and those for ships are included under 33 CFR Part 151. MARPOL is coordinated and enforced by the USCG in cooperation with other groups including:

- U.S. Department of Agricultural Animal and Plant Health Inspection Service (APHIS) and Plant Protection and Quarantine (PPQ) personnel
- Facility managers
- Port authorities
- Shipping agents
- Reception facilities
- Marina owners/operators
- Reservists
- Auxiliaries
- Local Coast Guard and station personnel
- National Marine Fisheries Service (NMFS)

Annex	Title
I	Regulations for Prevention of Pollution by Oil
II	Regulations for Prevention of Pollution by Noxious Liquid Substances (Chemicals) in Bulk
III	Regulations for Prevention of Pollution by Harmful Substances in Packaged Form
IV	Regulations for Prevention of Pollution by Sewage from Ships
V	Regulations for Prevention of Pollution by Garbage from Ships

Annexes I, II, and V have been incorporated into U.S. law by the Act to Prevent Pollution from Ships (33 CFR 151 and 46 CFR).

Annex III was implemented by the Hazardous Material Transportation Act (49 CFR 171, 172, 173, 174, and 176).

Annex V addresses the disposal of garbage from vessels. The highlights of Annex V are summarized below. Federal law makes it illegal to discharge plastics or garbage containing plastics into any waters.

Up to 3 miles offshore	Illegal to dump any garbage in lakes, rivers, bays, sounds, and up to 3 miles offshore
From 3 to 12 nautical miles offshore	Illegal to dump: <ul style="list-style-type: none"> • plastic • dunnage, lining, and packing materials that float • all other trash if not ground to less than 1 inch
From 12 to 25 nautical miles offshore	Illegal to dump: <ul style="list-style-type: none"> • plastic • dunnage, lining, and packing materials that float
Greater than 25 nautical miles offshore	Illegal to dump: <ul style="list-style-type: none"> • plastic

Bald and Golden Eagle Protection Act

This Act was passed to protect the bald and golden eagles, making it illegal to possess, sell, hunt, or offer to sell, hunt, or possess bald eagles.

Coastal Zone Act Reauthorization Amendments of 1990 (CZARA)

The amendments addressed the impacts of nonpoint source pollution on coastal water quality. Section 6217 “Protecting Coastal Waters” requires that each state with an approved coastal zone management program develop a coastal nonpoint pollution control program and submit it to EPA and NOAA for approval. The development and implementation of BMPs was seen as a primary control measure to reduce the impacts from activities associated with marinas.

Endangered Species Act of 1973 (ESA)

The ESA provides broad protection for species of fish and wildlife and plants that are listed as threatened or endangered in the U.S. or elsewhere. The ESA is administered by the USFWS and NMFS. The Act provides for the designation of critical habitat for listed species. The purpose of the ESA is to conserve the ecosystems upon which endangered and threatened species depend. *Endangered* is defined as any species that is in danger of extinction throughout all or a significant portion of its range. *Threatened* means a species is likely to become endangered within the foreseeable future. *Take* is defined as harass, harm, pursue, hunt, shoot, wound, kill, trap, capture, or collect or to attempt to engage in any such

conduct. Within this context, harm is defined as an act that actually kills or injures wildlife. Such act may include significant habitat modification or degradation where it actually kills or injures wildlife by significantly impairing essential behavioral patterns, including breeding, feeding, or sheltering.

Federal Water Pollution Control Act (FWPCA)

More commonly known as the Clean Water Act (CWA), this law has been expanded and amended over the years and covers a broad range of activities. Provisions of the law prevent and prohibit discharges of oil and hazardous substances in quantities that may be harmful; require that marine sanitation devices (MSDs) be installed on vessels with onboard fixed toilets; prohibit the discharge of raw sewage within U.S. waters; and established the National Pollutant Discharge Elimination System (NPDES) program. The Act also prohibits the use of chemical agents to disperse fuel, oil, or other chemicals without notification to and permission from the USCG. Section 404 of the CWA regulates the discharge of dredged and fill material into wetlands and Section 319 enabled the establishment of a national program to control nonpoint sources of water pollution.

Marine Mammal Protection Act (MMPA) (1972, Reauthorized 1994)

The Act establishes a federal responsibility to conserve marine mammals. The MMPA established a moratorium, with certain exceptions, on the taking of marine mammals in U.S. waters and by U.S. citizens on the high seas, and on the importing of marine mammals and marine mammal products into the U.S. Responsibility is divided between NMFS who manage cetaceans and pinnipeds other than walrus, and the USFWS, who is responsible for all other marine mammals, including sea otter, walrus, and polar bear.

Two important definitions to keep in mind when dealing with nuisance animals: (i) *Harassment* is defined as “an act of pursuit, torment or annoyance which has the potential to injure, or disturb by causing disruption of behavioral patterns, a marine mammal or marine mammal stock in the wild.” (ii) *Take* is defined as harass, hunt, capture, or kill, or attempt to harass, hunt, capture, or kill a marine mammal.

Marine Plastic Pollution Research and Control Act (MPPRCA)

This law implements Annex V of MARPOL. The primary emphasis of this law is to prohibit the discharge of plastics into waters anywhere, and it also restricts the at-sea discharge of garbage and other vessel wastes (see above). Under this law, ports must have adequate and convenient garbage “reception facilities” for vessels that do business with them. This includes transients. Vessels 26 feet or longer must display a placard that explains MARPOL 73/78 Annex V garbage dumping restrictions.

Marine Protection, Research, and Sanctuaries Act Title I (MPRSA)

This law implements the London Convention (International Convention on the Prevention of Marine Pollution by Dumping of Wastes and Other Matter) and generally prohibits, with some exceptions, the transportation and dumping of “material” into ocean waters.

National Pollutant Discharge Elimination System (NPDES) Storm Water Program—Storm Water Multi-Sector General Permit for Industrial Activities (MSGP)

EPA has implemented regulations requiring that storm water discharges associated with certain types of industrial activity be permitted. On April 16, 2001, EPA re-issued the MSGP (MSGP-2000) for facilities in Alaska. Regulated industrial activities include a group for Water Transportation (MSGP-2000, Sector Q). EPA uses Standard Industrial Classification (SIC) codes and Industrial Activity Codes to identify facilities that may require coverage. Industry Group 449—Services Incidental to Water Transportation—includes marinas (SIC 4493):

Establishments primarily engaged in operating marinas. The establishments rent boat slips and store boats, and generally perform a range of other services including cleaning, and incidental boat repair. They frequently sell food, fuel, and fishing supplies, and may sell boats. “Marinas” include: boat yards, storage areas and incidental repair; marinas; marina basins, operation of; and, yacht basins, operation of.

The requirement for a permit for storm water discharges applies to only those *facilities with vehicle (vessel) maintenance shops and/or equipment cleaning operations*. An important point to note is that

use of the tidal grid for routine maintenance activities such as hull scraping, sanding, washing, cleaning, and painting may require that a boat harbor obtain permit coverage. Exceptions would be use of the grid for changing zincs, doing minor prop and shaft work that does not disturb bottom paint, and marine surveys.

In addition to marinas, the requirement for a permit for storm water discharges associated with industrial activity from Water Transportation facilities includes facilities engaged in foreign or domestic transport of freight or passengers in deep sea or inland waters, marine cargo handling operations, ferry operations, and towing and tugboat services.

Compliance with the MSGP includes:

- Submittal of a notice of intent (NOI)
- Development, implementation, and maintenance of a storm water pollution prevention plan (SWPPP)
- Monitoring and reporting

National Pollutant Discharge Elimination System (NPDES)

The focus of the NPDES Storm Water Program is nonpoint sources of pollution. However, EPA's NPDES program also applies to industrial wastewater point source discharges. An NPDES permit may be required where a facility discharges wastewater directly to a surface water.

Oil Pollution Act of 1990 (OPA)

This act was developed in response to the *Exxon Valdez* oil spill. Under OPA, marinas are responsible for any oil contamination resulting from their facilities, including dumping or spilling of oil or oil-based paint and the use of chemically treated agents. In addition, any hazardous waste spill from a vessel must be reported by the vessel owner and the vessel owner is responsible for the costs of cleanup and any damage claims that result from the spill.

Appendix C

Trade and professional resources

This is list of trade and professional resources that I have had positive personal experience with in harbor operations and management. It certainly is not a complete list of every resource available to a harbormaster or marina manager, but represents a reliable group of professionals who can be used as a starting point for a manager researching a project or working on better development of a facility.

Alaska Association of Harbormasters and Port Administrators (AAHPA)

Kim Elliot, Executive Secretary
617 Katlian Street
Sitka, Alaska 99835-7300
(907) 747-4877 Fax: (907) 747-6278
www.alaskaharbors.com

Alaska Department of Transportation

Ports and Harbors Section
Vic Winters, State Coastal Engineer
3132 Channel Drive
Juneau, Alaska 99801-7898
(907) 465-3979 Fax: (907) 586-8365
www.dot.state.ak.us

ALX Technology (wireless remote access equipment)

Alex Francis
25A Embarcadero Cove
Oakland, CA 94606
(510) 535-2294 Fax: (510) 291-3252
www.alxtechnology.com

**American Boat Builders & Repairers Association (ABBRA)
(marine straddle hoist training)**

Mark Amaral, Managing Director
50 Water Street
Warren, Rhode Island 02885
(401) 247-0318 Fax: (401) 247-0074
mamaral@abbra.org

**Association of Marina Industries (AMI)/International Marina
Institute**

444 North Capitol St. NW, Suite 645
Washington, D.C. 20001
(866) 367-6622 Fax: (202) 628-8679
www.marinaassociation.org

ARXCIS, Inc. (crane safety and inspections)

LeRoy LaMar, General Manager
P.O. Box 689
Kingston, Washington 98346
(360) 297-3693 Fax: (360) 297-8388
www.arxcis.com

Florida Sea Grant Harbor Panic Preventer File

IFAS Extension Bookstore
University of Florida
P.O. Box 110011
Gainesville, Florida 32611
(800) 226-1764
www.ifasbooks.ufl.edu

Huff Limited (marine straddle hoist training)

Paul Doppke, Marina and Boatyard Consultant
415 County Road
Barrington, Rhode Island 02806
(401) 245-7063
HuffLtd@aol.com

Northern Economics, Inc.

Patrick Burden, Economist
880 H Street, Suite 210
Anchorage, Alaska 99501
(907) 274-5600 Fax: (907) 274-5601
www.northerneconomics.com

**Pacific Coast Congress of Harbormasters and Port Managers
(PCC)**

Cheryl and Cliff Maynard, Executive Secretary
120 State Ave., PMB 231
Olympia, Washington 98501
(800) 236-0748 Fax: (800) 236-3704
www.pcc-harbormasters.org

Peratrovich, Nottingham & Drage, Inc. (engineering)

John Pickering, P.E., and Doug Kenley, P.E.
1506 West 36th Avenue
Anchorage, Alaska 99503
(907) 561-1011 Fax: (907) 563-4220
www.pnd-anc.com

Transpac Marinas, Inc. (floating docks)

Kelly LaFave, P.E.
P.O. Box 1169
Anacortes, Washington 98221-1169
(360) 293-8888 Fax: (360) 293-8880

Tryck, Nyman, Hayes, Inc. (engineering)

John Daily, P.E., and Carl Stormer, P.E.
911 West 8th Avenue
Anchorage, Alaska 99501
(800) 770-0543 Fax: (907) 276-7679
www.tnh-inc.com

Acronym glossary

AAHPA	Alaska Association of Harbormasters and Port Administrators
ACOE	U.S. Army Corps of Engineers
ACZA	Ammoniacal copper zinc arsenate
ADA	Americans with Disabilities Act
ADAAG	Americans with Disabilities Act Accessibility Guidelines
ADEC	Alaska Department of Environmental Conservation
AMI	Association of Marina Industries
AWG	American wire gauge
AWPA	American Wood Preservers Association
BMP	Best management practice
CCA	Chromated copper arsenate
CFR	Code of Federal Regulations
DOT&PF	(Alaska) Department of Transportation and Public Facilities
EPA	Environmental Protection Agency
EPDM	Ethylene propylene diene monomer
EPS	Expanded polystyrene
GIS	Geographic information system
HAZWOPER	Hazardous waste operations and emergency response
HDPE	High density polyethylene
ICRI	International Concrete Repair Institute
IMI	International Marina Institute
LEPC	Local emergency planning committee

MLLW	Mean lower low water
MMPA	Marine Mammal Protection Act
NFPA	National Fire Protection Association
NMFS	National Marine Fisheries Service (NOAA Fisheries)
NOAA	National Oceanic and Atmospheric Administration
O&M	Operations and maintenance
OSHA	Occupational Safety and Health Administration
PCC	Pacific Coast Congress of Harbormasters and Port Managers
PND	Peratrovich, Nottingham & Drage, Inc.
P&P	Policies and procedures
PPE	Personal protective equipment
PWB	Permeable wave barrier
SPCC	Spill prevention control and countermeasure plan
UHMW	Ultra-high molecular weight polyethylene
UL	Underwriters Laboratory
USFWS	U.S. Fish and Wildlife Service
USCG	U.S. Coast Guard
VFD	Valdez Fire Department
VSBH	Valdez Small Boat Harbor

Index

Italics represents photo or illustration, and description.

A

AAHPA (Alaska Association of Harbormasters and Port Administrators) viii, 1, 112, 126, 144

Acknowledgments ix

Americans with Disabilities Act compliance 130

B

batteries, lead-acid, handling 49

berthing and storage of vessels 20, 26

best management practices, hazardous materials 38

Best Management Practices/ Environmental Concerns 40

blocking vessels, safety 26

breakwaters 67

cost 70

floating 72

permeable wave 68

rubble-mound 67

C

Clean Water Act 39, 138, 141

concrete floating docks 56

concrete, as a construction material 103, 104

degradation 105

maintenance and repair 105

contaminated fuel or water 47

copper arsenate 92

corrosion, inspecting for 99

galvanic 120

wood-metal 88

cranes, dockside 109, 111

inspections 110, 145

creosote 92

D

decay, wood 90

decay agents 78

inspecting for 93, 94, 95, 96

prevention 89

Dennis Nottingham's Method of

Inspection for Open Cell

Steel Bulkheads 99

docks

concrete floating 56, 57, 104

fixed 58, 59

galvanized sheet pile 102

wood floating 54

inspecting 55

E

- earthquake
 - damage *36, 71*
 - safety *35*
- economic impact of the harbor
 - 12*
- electrical systems *118*
 - meter base on dock *119*
 - policies *26*
 - transformer *121*
- electrical wiring and equipment
 - fire safety *17,19*
 - harbor facility safety *26*
 - pedestrian safety *32*
- electrolysis/corrosion *119*
- Endangered Species Act *34,140*

F

- fire fighting equipment *19, 23, 24*
- fire safety *14, 27*
 - plan *16,18, 24*
 - training *15*
- Fire Safety Plan for Valdez
 - Small Boat Harbor *18*
- fish cleaning stations *50, 51, 72, 73, 74*
- fish waste *50*
- fishing nets and fishing lines as solid waste *44*
- foam flotation *106*
 - test for *107*
- fuel, contaminated *47*
- fueling procedures *21, 22*

G

- galvanic corrosion *120*
- Galvanic Series Chart *101*
- gangways *24, 75, 76*
- garbage, handling *52*
- gribbles (marine borers) *86*

H

- hazardous materials *38*
 - training *52*
 - wood preservatives *92*

I

- insects, cause of wood damage
 - 79*
- inspections, harbor facility *8*
 - monthly checklist *11*

L

- launch ramps *64, 67*
 - guidelines *65*
- lighting systems *122*
 - float mounted *123*
 - high mast lights *123*
 - night lighting *122*
 - piling mounted *124*
- lighting, and safety *33*

M

- marine borers, cause of wood damage *83*
- marine mammal protection *141*
- marine mammals in the harbor
 - 33, 34*
- MARPOL *44, 52, 138, 142*
- Moorage Agreement, Valdez *6*
- moorage rates *12*
- mooring docks *54*

O

- oil, used, collection of *41*
- OSHA monthly checklists *9*

P

- paint removal *27, 45*
 - hull scraping and sanding *46*
- paint, liquid and aerosol,
 - proper use *48, 49*
- pentachlorophenol *92*

personal flotation devices
(PFDs) 30

Kids Don't Float 31

pholads (marine borers) 85

pilings, anchor 60

open-cell sheet 60

steel 61

pollution

MARPOL 44, 138

nonpoint source 137

Oil Pollution Act 143

port security 126

R

References 128

ring life buoy 28, 29

S

safety ladder 29, 30

safety

floating dock freeboard 28

harbor facility 25

power system 25

water rescue equipment 29

salt degradation of wood 88

scrap materials, handling 47

security, port 126

Seven day Hunt absorption test

for foam dock flotation 107

sewage pumpout station 46

shipworms 84

Sorum, Alan *viii*

steel as a construction material

98, 102

corrosion 98

inspection 99

straddle hoists 112

T

throw bags 29

tidal grids 62, 63

training employees 126

marine straddle hoist training
145

trash, handling 52

Travelifts 112, 114

tsunami

damage 36, 71

safety 35

U

U.S. Coast Guard 127

V

Valdez Boatyard Policies 26

Valdez Harbor Launch Ramp

Guidelines 65

Valdez Moorage Agreement 6

Valdez Small Boat Harbor

Monthly Facility Inspection

Checklist 10

W

waste materials

handling 43

plastic wastes 44, 45, 142

water, contaminated 47

oily bilge water 48

storm water discharge 142

water, potable systems 115

hose bibs 115

hose hanger 116

wave barrier, sheet pile 69

wood preservatives 91

wood, as a construction

material 77

damage agents living 78

damage agents nonliving 88

repair 97